



HPTB/32/ABB1B-01

Installation Manual

Disclaimer

While the HART Interface Solution (HIS) Replacement Panels from Pepperl + Fuchs, Inc. (“HIS Replacement Panels”) are designed to extract the digital HART data from standard 4-20mA loops, the HIS Replacement Panels may not provide all of the features, or duplicate all the functions, of the panels they replaced, and Pepperl + Fuchs, Inc. makes no warranty or representation (and specifically disclaims any express or implied warranty or representation) that such HIS Replacement Panels are identical to, or will provide all of the same features or duplicate all of the same functions of, the panels they replace. The terms, conditions and limitations of any product warranties covering HIS Replacement Panels may be obtained from Pepperl + Fuchs, Inc.

The information set forth in this Manual is designed to assist the Purchaser in the installation, operation and maintenance of an HIS Replacement Panel. Such information should not be construed as a warranty or representation, express or implied, regarding the HIS Replacement Panel or its use in, or suitability for, a particular application, any such warranties or representations being specifically disclaimed. The terms, conditions and limitations of any product warranties covering HIS Replacement Panels may be obtained from Pepperl + Fuchs, Inc. Pepperl + Fuchs, Inc. reserves the right to modify or improve the designs, specifications, features and/or functions of HIS Replacement Panels at any time without notice.

Copyright and Trademark Information

This manual is copyright of Pepperl+Fuchs with all rights reserved. This manual may not be copied, in whole or in part, without the written consent of Pepperl+Fuchs.

Pepperl+Fuchs reserves the right to make changes to this manual without notice.

Asset Management Solutions (AMS) is a registered trademark of Fisher-Rosemount Systems.

HART is a registered trademark of the HART® Communication Foundation.

Windows is a trademark of Microsoft Corporation.

All other marks are property of their respective owners.

Table of Contents

1.	General Description	5
1.1	Introduction	5
1.1.1	Purpose	5
1.1.2	Functions	5
1.1.3	HART Overview	5
1.1.4	Specifications	6
1.1.4.1	2700 MUX Specifications	6
1.1.4.2	HPSM Termination Board Specifications	6
1.1.4.3	RS-485 Line Specifications	7
1.2	Asset Management Solutions Software	8
1.3	Associated Tools and Test Equipment	8
1.4	Quality Assurance	8
1.5	Certifications and Compliance	8
1.6	Unpacking and Inspection	8
1.7	Storage	9
2.	Installation	9
2.1	Environmental Conditions	9
2.2	Intrinsic Safety	9
2.3	Mounting	9
2.4	Cables	9
2.5	Wiring	10
2.5.1	Power	10
2.5.2	RS-485	11
2.5.3	Field Connections	12
2.5.4	Control Connections	12
2.5.5	HART Communicator	12
2.6	Grounding	12
3.	Operation	12
3.1	Initial Setup	12
3.1.1	2700 Settings	13
3.1.1.1	Address	13
3.1.1.2	Baud Rate	13
3.1.2	RS-485/RS-232 Converter	14
3.2	Start-up Sequence	14
3.3	Controls	14
3.4	Indicators	15
3.5	Modes of Operation	15
4.	Theory of Operation (Principles of Operation)	16
4.1	Multiple Multiplexers	16
5.	Troubleshooting	16
5.1	2700 MUX	17
6.	Maintenance	17
7.	Parts List	18
8.	Glossary	18
9.	Contact Information	19

Figures

Figure 1. HPTB/32/ABB1B-01 Layout	7
Figure 2. Simplified Schematic	10
Figure 3. RS-485 Wiring	11
Figure 4. 2700 MUX Labels	14
Figure 5. 2700 MUX Block Diagram	16

Tables

Table 1. Maximum Wiring Lengths	11
Table 2. RS 485 Baud Rate	13
Table 3. RS 485 Address	14
Table 4. Jumper Selection	15
Table 5. 2700 MUX LED Indications	17
Table 6. Replaceable Parts	18

1. General Description

1.1 Introduction

This manual provides guidance for the installation, operation, and maintenance of your P+F 2700 Multiplexer, and termination board model number, HPTB/32/ABB1B-01. This solution is specifically designed for easy Multiplexer integration with ABB I/O Modules DSAI133 and DSAX110.

The P+F 2700 Multiplexer will be referred to in this manual as the 2700 MUX. All further references to the HPTB/32/ABB1B-01 will be simply HPTB. When referring to the two units as a whole, they will be called the HART Interface Solution, or simply HIS.

To avoid damage, failure, or improper operation, read this manual carefully before installing and operating the equipment.

1.1.1 Purpose

The 2700 MUX is a HART signal multiplexer unit, which allows access to HART communication on existing 4-20mA wiring.

1.1.2 Functions

Your HART Interface Solution interfaces up to 32 field located HART devices. The 2700 MUX is the heart of the system. It acts as a gateway device, routing communications between the maintenance workstation PC and the HART devices. The 2700 MUX uses the HART protocol on both the RS-485 link to the maintenance workstation PC and on the Bell 202 Frequency Shift Keying (FSK) link (base HART protocol) to each of the HART devices. It interrogates each HART device, retrieves device information, and stores it in an internal database. This information is available to the maintenance workstation software.

Furthermore, the 2700 MUX acts as a message coordinator for communication between the maintenance workstation PC and the HART devices. In this way, the 2700 MUX is transparent to the user. In fact, the user has access to each HART device as if connected directly at the device itself. Additionally, the 2700 MUX may be connected in a HART RS-485 multidrop network. A maintenance workstation PC can use this multidrop network for configuration, maintenance, calibration, diagnostics, and data access.

HART Interface Solutions are supplied by P+F with several models in order to allow simple and reliable connection with Smart devices.

1.1.3 HART Overview

HART is an acronym for "**H**ighway **A**ddressable **R**emote **T**ransducer". The HART protocol makes use of the Bell 202 FSK standard to superimpose digital signals at a low level on top of the 4-20mA signal. This enables two-way communication and makes it possible for additional information beyond just the normal process variable to be communicated to/from a smart field instrument. The HART protocol communicates without interrupting the 4-20mA signal and allows a host application (master) to get two or more digital updates per second from a field device. As the digital FSK signal is phase continuous, there is no interference with the 4-20mA signal.

1.1.4 Specifications

1.1.4.1 2700 MUX Specifications

POWER SUPPLY: 24 VDC (-15%, +25%)

SUPPLY CURRENT: 20VDC, 32mA (typical, RS485 quiescent)
24VDC, 28mA (typical, RS485 quiescent)
30VDC, 23mA (typical, RS485 quiescent)

MODULE CONNECTION: 2, plug-in, 40-poles miniature connectors

EMC: EN50081-2, EN50082-2

ISOLATION: 1500Vrms for 1 minute

ENVIRONMENTAL CONDITION LIMITS:

Operating temperature: 0 to 55°C (32 to 131°F)

Storage Temperature: -20 to 70°C (-4 to 167°F)

Relative Humidity: 5 to 90% non-condensing

SIGNAL CHANNELS: Up to 32 signal pairs unbalanced

DC-ISOLATION: Dual capacitor isolation in each loop

ALLOWED COMMON MODE VOLTAGE: Up to 30V

DIFFERENTIAL MODE CLAMPING: +/- 5.2V (for transient or AC signals)

RECEIVE SIGNAL RANGE: 0.12Vpp < signal < 1.5Vpp

RECEIVE IMPEDANCE: >5000Ω

CARRIER DETECT LEVELS: Signal > 0.12Vpp – CD asserted

Signal < 0.080Vpp – CD not asserted

TRANSMIT SIGNAL AMPLITUDE: 200Ω load – 0.43Vpp < signal < 0.49Vpp

500Ω load – 1.1Vpp < signal < 1.2Vpp

CARRIER STOP TIME: <10 bit time

DEVICE CONNECTION TYPE: Secondary Device (DC-isolated bus device)

IMPEDANCE LEVEL TYPE: High impedance device

DATA LINK TYPE: Primary or Secondary master (configurable)

FIELD MULTI-DROP SUPPORT: Available on request

1.1.4.2 HPTB Termination Board Specifications

MOUNTING: Mounts to standard T-type (EN50022 (DIN46277-3)) or G-type (EN50035 (DIN46277-1)) DIN rail.

CONNECTIONS: Phoenix Contact 5.08mm screw terminals for power, RS-485, and field connections; 4-40 Screw terminals for shield connections; Four 26 pin connectors for DCS cable.

POWER FUSE: 2A, 5x20mm

DIMENSIONS: (See Figure 1)

Length = 13.1" (333mm)

Width = 5.0" (127mm)

Height = 2.25" (57mm) [6.5" (165mm) w/MUX installed]

HPTB/32/ABB1B-01 Layout

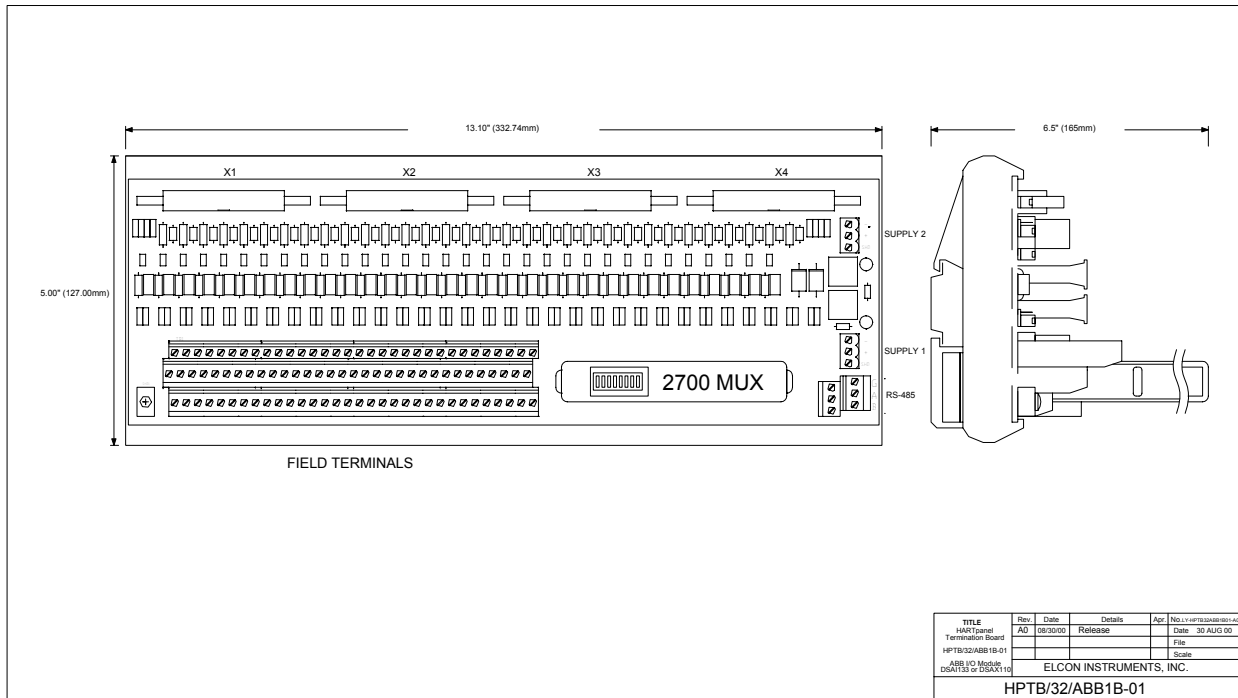

Figure 1

1.1.4.3 RS-485 Line Specifications

COMMUNICATION PORT: RS-485 differential pair (isolated). An RS-232 to RS-485 converter is needed to connect the PC host station to the board Terminal block (see Figure 3).

DIGITAL COMMUNICATION SPEED: 9600 bps or 19200 bps (user selectable)

MULTI-DROP ADDRESSING: up to 31 2700 MUX modules (32 channels each)

MULTI-NETWORK OPERATION: Available within software options

MAXIMUM NUMBER OF 2700 MULTIPLEXERS IN NETWORK: 31

NETWORK TOTAL: 992 per Serial Line

MULTI-NETWORK OPERATION: 4 Serial Lines; Available within maintenance software package

SMART PROTOCOL PRESENTLY SUPPORTED: HART

OUTPUT NETWORK: RS-485 (use an RS-232 to RS-485 converter Keithley type M1000 to connect the PC maintenance station).

BAUD RATE: 9600 bps or 19200 bps (user selectable)

TOTAL NUMBER OF BITS: 11 bits

NUMBER OF DATA BITS: 8 bits

PARITY: ODD

NUMBER OF STOP BITS: 1 bit

TRANSMISSION TYPE: 2-wire

1.2 Asset Management Solutions (AMS) Software

AMS software provides an easy-to-use means for integrating various device management software packages into a unified system. AMS operates under the Microsoft® Windows® format. It combines the various device (or asset) management tasks into an application with a common look-and-feel and centralized data storage.

AMS provides access to functionality available via the HART communications protocol for any HART device whose Device Description (DD) is registered with the HART Communication Foundation.

For more information on installation of AMS software, consult the AMS Installation Guide.

1.3 Associated Tools and Test Equipment

No special tools or test equipment are required.

1.4 Quality Assurance

All Pepperl+Fuchs production is performed under a Quality Assurance program following written procedures, which are specific for each line of instruments, during the manufacturing, intermediate testing and inspection, and final inspection phases.

Each 2700 MUX unit undergoes accelerated thermic aging (burn-in) for a minimum 200 hours at 50°C (122°F) with at least 1 cooling thermic cycle at 0°C (32°F) and back to 50°C (122°F). The purpose is to identify weak components that may develop initial fault mechanisms due to "Infant Mortality". Only after a positive burn-in test, instruments undergo a complete final inspection performed with computerized automatic testing equipment specifically developed by P+F for this purpose.

1.5 Certifications and Compliance

HART Interface Solutions are CE compliant.

This Equipment is suitable for use in Class I, Division 2, Groups A, B, C, and D or non-hazardous locations only. Equipment must be mounted in an enclosure that meets the requirements of ANSI/ISA S82.01 & S82.03 and the National Electrical Code.

1.6 Unpacking and Inspection

Upon receipt of the materials, you should check the integrity of the packing and the contents. In case of damage due to shipping, you should promptly and properly report to the shipper, supplying all necessary information.

If instruments are not for immediate use, we recommend that you check that all characteristics shown on the instruments label meet order specifications (model, supply voltage and frequency, input/output range, certification, tag etc.) as well as the actual application requirements.

If not installed, equipment should be stored following recommendations of the next section.

1.7 Storage

In case of storage of instruments and accessories, proper care should be taken to protect them from any possible damage. Always store instruments in their sealed original packaging until they are installed.

Provide adequate protection to prevent damages that may be caused by exposure to:

- Rain, excessive humidity and/or temperature excursions (inadequate sheltering).
- Dust (build-up of a corrosive patina that may cause oxidations and reduce isolation).
- Aggressive and polluting atmospheres with consequent corrosion.
- Access by insects/rodents (damage of packing or content).
- Mechanical shocks or unauthorized packing opening.
- Intense vibrations (loosening of fastened parts, fatigue failures, etc.).
- Any other possible risk.

Make sure the storage temperature does not exceed the limits of -20 to $+55^{\circ}\text{C}$ (-4 to 131°F) for medium/long term storage (days/months) and -25 to $+75^{\circ}\text{C}$ (-13 to 167°F) for short term storage (a few hours) transportation/shipment.

If inspection is completed, pack instruments in their original packing. List the contents on the packaging to avoid unnecessary further inspections.

2. Installation

2.1 Environmental Conditions

HIS products, like most modern electronic equipment, can operate in wide temperature and humidity ranges. However, practical consideration suggests a guideline on operating environment for best results.

- Keep operating temperature below 35°C (95°F), ideally between 20°C and 25°C (68 and 77°F), avoiding wide and rapid temperature excursions.
- Control relative humidity within 40 to 60% to avoid risks of static charges or condensation.
- Limit the presence of corrosive atmosphere, fumes and dust, sealing and purifying the control room area and using air filters in the cabinet air intakes (clean cable entry path), if necessary.
- Reduce vibrations (if any) to safe levels.

2.2 Intrinsic Safety

The HIS system can interface HART devices located in Hazardous areas by interposition of suitable galvanically isolated Intrinsically Safe Barriers. The barriers must allow bidirectional HART signal communication in addition to the normal 4-20 mA loop current processing.

2.3 Mounting

The 2700 MUX is a plug-in unit that must be inserted in the appropriate termination board position. Exercise care in the insertion to mate the connector's pins, then firmly press the module to engage the connector. Use P+F's simple "Quick-Lock" mechanisms on each end of the module to secure it to the termination board.

The HPTB is designed to be mounted on T-type or G-type DIN rail. The board should be mounted near the marshalling panels or termination panels.

2.4 Cables

Connectors X1 through X4 are for DCS cable connection. X2 & X4 are for redundant connections. These connectors share the same designation and pin-out as the standard ABB termination board connectors.

Simplified Schematic

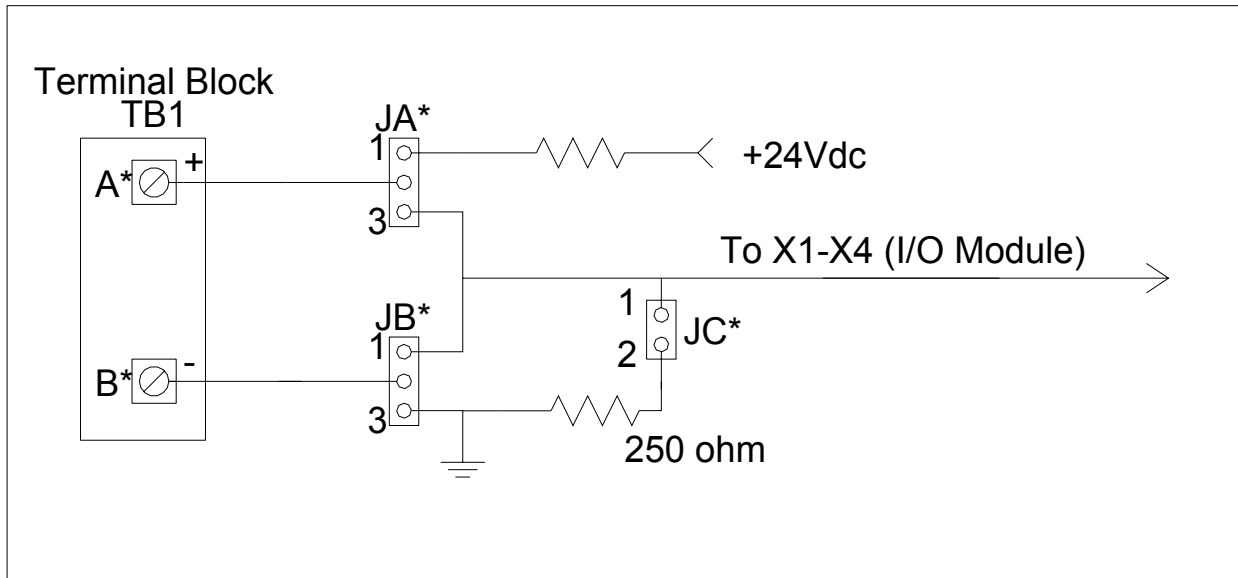

Figure 2

2.5 Wiring

The 2700 MUX is a plug in unit and is connected to the HPTB by a multipole connector. Therefore, all electrical connections (supply, field connection, serial lines, etc.) are made at the termination board unit. Refer to Figure 2 for a simplified representation of wiring and jumper settings.

2.5.1 Power

Connect 24 VDC to the 3-pin removable terminal at the end of the HPTB. The connector is polarized, so you cannot insert it incorrectly. The polarity is marked on the board and the terminals.

WARNING! Improper supply connections can seriously damage the instrument and result in risk of fire or explosion in hazardous locations!

DC SUPPLY REQUIREMENTS: Check correct polarity of supply line, making sure that voltage excursions never go lower than 21.5 V (including ripple effect) or higher than 28 V.

WARNING! Note that a crude, poorly filtered or unregulated supply can produce destructive (hundreds of volts) voltage spikes during supply transformer switch-off transient; this could cause minor problems to electro-mechanical components like relays or solenoids but will surely degrade or destroy electronic equipments. In case of doubt, provide over-voltage limiting by adequately dimensioned surge arresters on primary winding and voltage limiters (power zeners, zenamic, etc.) on the DC supply line to limit transients within 30-35V peak.

SUPPLY CONDUCTORS SIZING:

A single unit requiring 100 mA will have a conductor sizing based on mechanical strength rather than current carrying capacity. A reverse polarity shunt diode and series fuse protection are provided to avoid damaging the module in case of accidentally reversed polarity connection. In this case, the reverse voltage is clamped at -0.6 V and the T.B. slow blow fuse blows. Restore correct supply polarity and replace the blown fuse with the spare one supplied in the T.B. spare fuse holder (take care to reinstall a good, properly sized, new spare fuse!).

2.5.2 RS-485 (See Table 1)

RS-485 wiring is connected as shown in Figure 3. These wires carry data from the HIS to the PC via an RS-485/RS-232 converter. Connect the converter to a serial port on the PC as indicated in the converter’s documentation.

Table 1
Maximum Wiring Lengths

Communication Protocol	Maximum Cable Length	
	Feet	Meters
RS-232	50	15
RS-485	4000	1200
HART	900 to 6500	275 to 2000

RS-485 cable length can be increased if high performance cables are used.

HART cable length depends on the capacitance of the cable and device, and the load resistor. The general rule is: $R \times C < 65\text{ms}$. Consult “HART- A Technical Description” for more details. This is a free document published by the HART Communication Foundation.

RS-485 Wiring

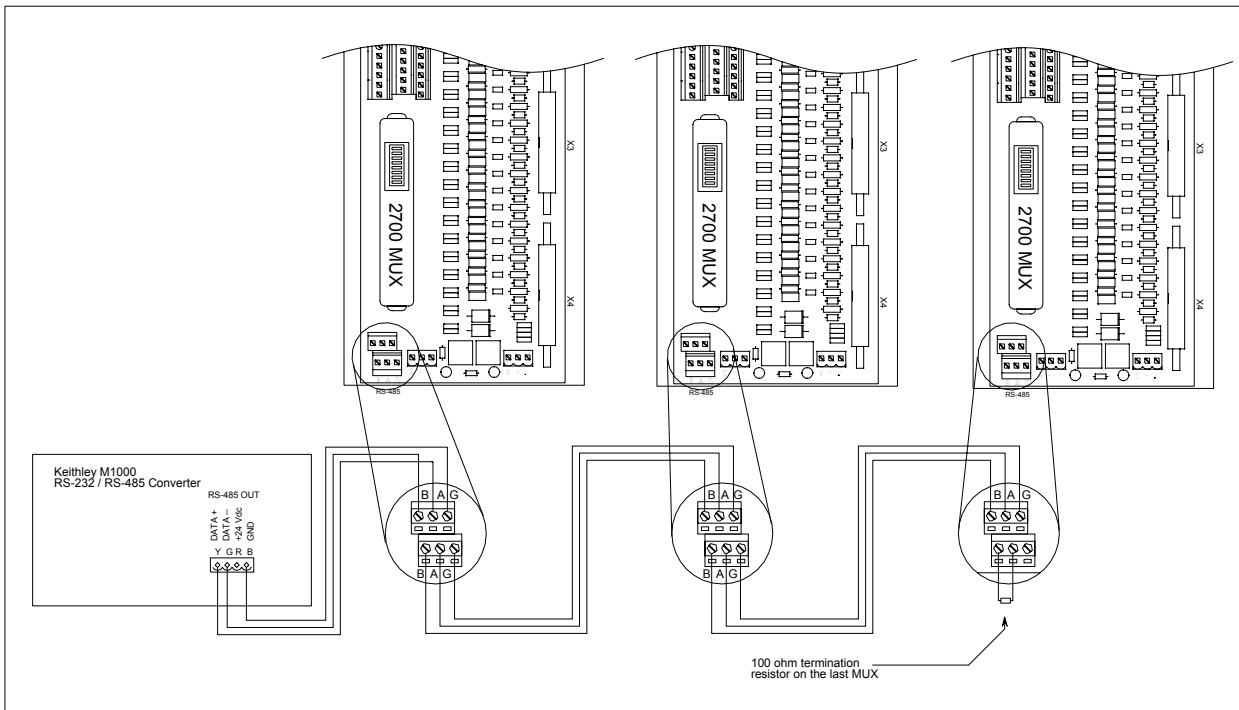

Figure 3

2.5.3 Field Connections

All field wiring is connected via the three-tiered terminal block TB1. Each channel is one vertical column. The alphabetical designations are as follows:

A= Positive
B= Negative
C= Shield

2.5.4 Control Connections

The HPTB provides simplex and redundant connectors (X1-X4) for connection directly to ABB I/O Module DSAI133 or DSAX110. No adapter or accessory hardware is required.

2.5.5 HART Communicator

In HART communications, there is one slave (field device) and up to two masters (e.g. Multiplexer, HART Communicator, I/O module). The HART Communicator can be connected to the field side terminals as a secondary master. In your software settings, the 2700 MUX must be the primary master in order to use the HART Communicator.

There cannot be more than two masters. If three or more masters are connected, a primary/ secondary conflict will occur and communications will cease with all devices on that loop. When the 2700 MUX is used with a HART compatible I/O system, the 2700 MUX must be configured as the secondary master. Otherwise, configure the 2700 MUX as the primary master. The HHT is a secondary master by default, and can be connected to the loop when no other device on that loop is configured as a secondary master.

WARNING! Do not connect the HART Communicator to any Intrinsically Safe field wiring unless the terminal is approved as Intrinsically Safe and suitable for the actual hazardous location classification of the specific hazardous location. Also consider HART Communicator safety parameters and equivalent capacitance and inductance before concluding that you can safely connect it to the I. S. side of the circuit.

2.6 Grounding

The HPTB provides one shield terminal per channel. These terminals are connected to SHD1, which provides a single point to properly ground field wiring cable shields. This terminal may not be necessary to use, but is available for different applications.

3. Operation

3.1 Initial Setup

The default settings for each 2700 MUX are as follows:

Address = 1
Baud Rate = 19200

3.1.1 2700 Settings (See Figure 4)

The User Switches buffer has eight inputs from a low profile DIL switch reachable through the front label. The functions of the switches are as follows:

Switch 7	(T)	Reserved for TEST purposes
Switch 6	(R1)	BAUD RATE 1
Switch 5	(R0)	BAUD RATE 0
Switch 4	(B4)	ADDRESS 4
Switch 3	(B3)	ADDRESS 3
Switch 2	(B2)	ADDRESS 2
Switch 1	(B1)	ADDRESS 1
Switch 0	(B0)	ADDRESS 0

Further information is given on the front and side labels (Figure 4). In particular, the side label gives the correct setting of every DIP switch combination.

3.1.1.1 Address

The address of the 2700 MUX is determined by the DIP switches as noted below (Table 4). Each MUX on the same RS-485 network must have a different address, but they do not have to be sequential and do not necessarily need to start at address 1. Possible addresses are 1-31. Address 0 is invalid and cannot be used. Note that network properties of the software setup refers to “multi-dropping.” This refers to multiple 2700 MUXs on the same network, not multiple devices on the same I/O loop (also referred to as “multi-dropping”). Multi-dropping should be enabled in the network setup.

3.1.1.2 Baud Rate

RS-485 BAUD RATE

	SW 6	SW 7
9600	ON	OFF
19200	OFF	OFF

Table 3

The baud rate of the 2700 MUX must match the baud rate of the PC Com-Port and the RS-232/RS-485 converter. All three units must have the same baud rate to function properly. The baud rate can be either 9600 or 19200 and is selected as shown in Table 3.

2700 MUX Labels

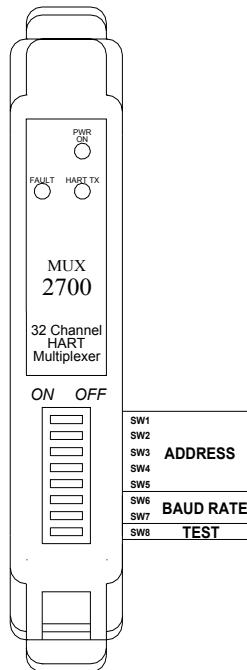

Figure 4

RS-485 ADDRESS

	SW1	SW2	SW3	SW4	SW5		SW1	SW2	SW3	SW4	SW5
0	OFF	OFF	OFF	OFF	OFF	16	OFF	OFF	OFF	OFF	ON
1	ON	OFF	OFF	OFF	OFF	17	ON	OFF	OFF	OFF	ON
2	OFF	ON	OFF	OFF	OFF	18	OFF	ON	OFF	OFF	ON
3	ON	ON	OFF	OFF	OFF	19	ON	ON	OFF	OFF	ON
4	OFF	OFF	ON	OFF	OFF	20	OFF	OFF	ON	OFF	ON
5	ON	OFF	ON	OFF	OFF	21	ON	OFF	ON	OFF	ON
6	OFF	ON	ON	OFF	OFF	22	OFF	ON	ON	OFF	ON
7	ON	ON	ON	OFF	OFF	23	ON	ON	ON	OFF	ON
8	OFF	OFF	OFF	ON	OFF	24	OFF	OFF	OFF	ON	ON
9	ON	OFF	OFF	ON	OFF	25	ON	OFF	OFF	ON	ON
10	OFF	ON	OFF	ON	OFF	26	OFF	ON	OFF	ON	ON
11	ON	ON	OFF	ON	OFF	27	ON	ON	OFF	ON	ON
12	OFF	OFF	ON	ON	OFF	28	OFF	OFF	ON	ON	ON
13	ON	OFF	ON	ON	OFF	29	ON	OFF	ON	ON	ON
14	OFF	ON	ON	ON	OFF	30	OFF	ON	ON	ON	ON
15	ON	ON	ON	ON	OFF	31	ON	ON	ON	ON	ON

Table 3

3.1.2 RS-232/RS-485 Converter

An RS-232 to RS-485 converter must be placed between the HIS and the computer's RS-232 port. P+F recommends the Keithley M1000 for non-CE applications.

If only one RS-232 to RS-485 converter is used in setting up the system, then the RS-485 network must be less than 1200 meters (4000 feet). If the network surpasses 4000 feet, an RS-232 to RS-485 repeater can be used. The Keithley M1000 can fulfill this function. The repeater amplifies the original RS-485 signal when it is transmitted over long distances.

3.2 Start-up Sequence

Proper start-up sequence for the 2700 MUX is as follows:

1. Make all field and control connections to the HPTB
2. Connect RS-485 wires and adjust network settings
3. Apply field power or source 4-20mA
4. Turn on power to or plug in the 2700 MUX
5. After the 2700 MUX has completed the start-up sequence, then start AMS

3.3 Controls

Each channel of the HIS board can accommodate either smart 2-wire transmitters or smart valves. Both devices are connected to the terminal blocks in the same manner. However, there are three jumpers per channel on the HPTB that must be set for proper operation. In addition, Jumpers J1-4 and J5-8 determine which I/O module type may be plugged in to X1-X4. Note that any one HPTB can accommodate either two DSAX110, two DSA1133, or one of each. The only determining factor is the placement of J1-J8. Please refer to Table 4 below.

Table 4
Jumper Selection

Jumper	Analog Input Position	Analog Output Position
JA*	1-2	2-3
JB*	1-2	2-3
JC*	ON	OFF
	DSAI133	DSAX110
J1-J4 (Channels 1-16)	1-2	2-3
J5-J8 (Channels 17-32)	1-2	2-3

3.4 Indicators (See Figure 4)

Three LEDs on the front of the 2700 MUX indicate status. Normal operation is as follows:

- Power ON: Green LED lit when power is applied to the 2700 MUX. Power is automatically applied when the 2700 MUX is plugged into the HPTB.
- Tx: Shows 2700 MUX communication with field devices.
- Fault: Fault LED should not be lit during normal operation.

One LED on the termination board is a power indication showing 24 VDC available.

3.5 Modes of Operation

- SCAN MODE: Command to the 2700 MUX from the software telling the 2700 MUX to periodically scan each device automatically. Otherwise, the 2700 MUX will only communicate with a device when told to do so by the software.
- BURST MODE: When a field device is in burst mode, it automatically sends information without being commanded to do so. This is a break from the master-slave nature of HART communication, but the 2700 MUX will support it when burst mode is selected in the software.

4. Theory of Operation (Principles of Operation)

Referring to Figure 5, the heart of the 2700 MUX is the microprocessor. One serial port together with the HART modem generates the physical layer of the HART protocol, while the channel select circuit together with the channel multiplexer links one specific channel (device) at a time. An RS-485 circuit completes the gateway between the maintenance workstation PC and the devices. The user switches circuit provides information required by the 2700 MUX for initialization and configuration. Specifically, the baud rate for communications to the maintenance workstation PC and the 2700 MUX address are selected.

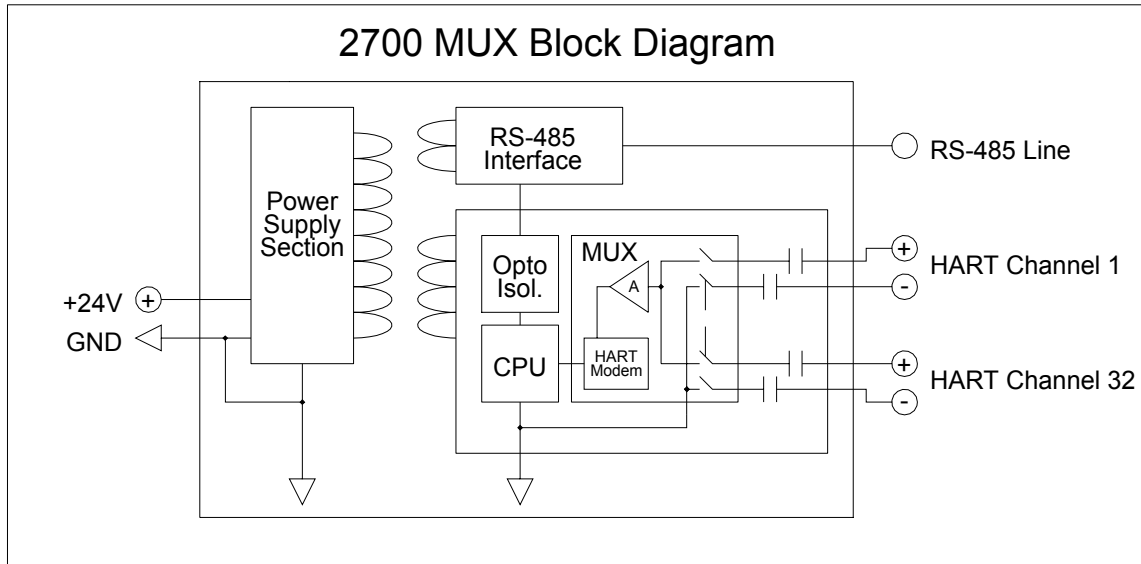

Figure 5

4.1 Multiple Multiplexers

Up to 31 2700 MUXs can be connected on a single RS-485 network to support 992 devices. Multiple 2700 MUXs are connected in daisy-chain form, and redundant terminals are provided for this on each board.

5. Troubleshooting

Due to the modular nature of the HIS system, a communication failure may occur anywhere in the data transfer link from the software to the field device. In order to identify where the loss of communication has occurred, it is important to understand which components are working correctly. Often, some simple checks will save hours of troubleshooting. Some of the most common mistakes are: improper wiring connections, baud rate mismatches, improper network settings, and improper addressing of the 2700 MUX.

5.1 2700 MUX

The LEDs at the front of the 2700 MUX provide a convenient indication to the user that the 2700 MUX is operational. During normal operation, the “Power On” light should be on. The “Fault” light should be off. The “Tx” light may either be off or flashing steadily.

When power to the 2700 MUX is cycled or a “Reset” command is issued, all the lights will come on. Then, the “Power On” light only will come on. For the next 60 to 120 seconds, the “Tx” light will flash three times then pause. During this time, the 2700 MUX is scanning each of the 32 channels. When it is finished, the “Tx” light will either flash steadily or turn off altogether. If you see all of the above occur, the 2700 MUX is operating properly.

In addition, the TEST setting on the option switches can be used to gain confidence that the module is functioning. Follow the procedure below to use this feature:

1. With the power off, set the end switch to the TEST position (ON). The module should not be connected to the RS-485 network, the RS-485 address switches have no effect. If an RS-485 terminal is connected to the module, the BAUD rate switches should be set.
2. Switch power on. The LEDs should light for about 1 second each in sequence (RED, YELLOW, GREEN...).
3. If the LEDs do not flash, there is a fault with the module and it should be returned for replacement.
4. To return to normal operation, remove power to the 2700 MUX and set the TEST switch to the off position. Ensure that the correct BAUD rate is selected and that an RS-485 address is set. Then, re-apply power.

If you suspect the 2700 MUX is not functioning properly, use Table 5 below.

Table 5
2700 MUX LED Indications

Symptom	Cause	Solution
Lights flash sequentially	TEST switch is ON	Switch off the power Put TEST switch OFF Restart the system
No LEDs lit	Power fail or fuse open	Check 24 VDC supply LED and fuse
Only yellow LED lit	Scanning is disabled. If scanning is enabled, then no HART devices were detected by the 2700 MUX	Check wiring continuity
Red LED lit	Self-test fault	Contact Pepperl+Fuchs for further instructions

6. Maintenance

Pepperl+Fuchs apparatus do not require any particular maintenance under normal operating conditions. They are designed to operate trouble-free and with high stability for long periods.

WARNING! Any repair made by unauthorized personnel may completely invalidate the safety characteristics of the unit and could void all warranties. Repair not made by Pepperl+Fuchs is fully at user's risk and responsibility. In addition, the warranty terms of the unit will be null and void to all effect.

7. Parts List

Table 6 is a representation of the parts on the HPTB that can be replaced by the user. There are no parts in or on the 2700 MUX itself that can be replaced in the field. If any other parts need to be replaced, please contact your nearest Pepperl+Fuchs representative for instructions.

Table 6
Replaceable Parts

Part Number	Description
501300	Supply ID label
502401	Terminal blocks MVSTBW 2.5/3-ST-5.08
507500	Jumper Shunt 0.100"
508112	Fuse 5x20 time-lag, 2 Amp F1
508200	Vertical fuse holder for 3.15 Amp F1

8. Glossary

DCS	Distributed Control System
FSK	Frequency Shift Keying
HART®	Highway Addressable Remote Transducer
HHT	Hand Held Terminal
IS	Intrinsic Safety
MW	Maintenance Workstation
PC	Personal Computer
PLC	Programmable Logic Controller
TB	Termination Board

9. Contact Information

International Headquarters

Europe

Pepperl+Fuchs GmbH
Königsberger Allee 87
Mannheim
68307 Germany
Phone: + 49 621 776-0
Fax: + 49 621 776-10 00
Email: info@de.pepperl-fuchs.com
Website: www.pepperl-fuchs.com

Regional Headquarters

Italy and Mediterranean

Pepperl+Fuchs Elcon - Head Office
Via delle Industrie, 4
Mezzago (Mi)
20050 Italy
Phone: ++39 039 6292 1
Fax: ++39 039 6292 290
Email: info@it.pepperl-fuchs.com
Website: www.elconinstruments.com

North America & South America

Pepperl+Fuchs Inc. - USA Headquarters
1600 Enterprise Parkway
Twinsburg, OH 44087
USA
Phone: +1-330 425 3555
Fax: +1-330 425 4607
Email: sales@us.pepperl-fuchs.com
Website: www.am.pepperl-fuchs.com

Asia Pacific

Pepperl+Fuchs Pte Ltd - Asia Pacific
P+F Building
18 Ayer Rajah Crescent
139942 Singapore
Phone: +65 779 90 91
Fax: +65 873 16 37
Email: sales@sg.pepperl-fuchs.com
Website: www.elconinstruments.com