

Technical Data

Connections

Wiring Options	
Field side	5.08mm removable screw terminals
Control side	50 pin Centronics cable connector
RS-485	5.08mm removable screw terminals

Electrical

Mounting	24 VDC
Power consumption	0.7 W
Power fuse	315mA, 5x20mm
DC isolation of HART	30 VDC

Mechanical

Mounting	T type (EN 50022, DIN462777-3) or G type (EN 50035, DIN462777-1) DIN rail
Signal Channels	Up to 32 unbalanced signal loops
Communication port	RS-485, differential pair plus GND
Communication speed	9600 or 19200 baud
Max. Conductor diameter	16 AWG (2.5mm ²)
Weight	25 oz. (510 g)
Dimensions	307mm x 120mm x 57mm (L x W x H) without mux 307mm x 120mm x 57mm (L x W x H) with mux

Honeywell IOP Interface

HPTB/32/HONB-AI-01	MU-PAIH01, MU-PAIH02 MC-PAIH02, MU-PAIH03
--------------------	--

Installation Instruction

Product installation manual	www.elconhis.com/customized-honeywell.html
-----------------------------	--

HART Interface Solutions

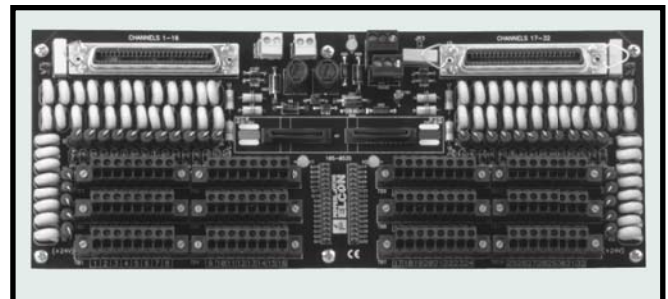

Model Number
HPTB/32/HONB-AI-01

- TDC 3000 FTA replacement
- Short circuit protected
- DCS connections
- Redundant power supply connections
- Field terminal blocks that are Honeywell FTA compatible
- Honeywell "B" size footprint

The HPTB/32/HONB-AI-01 is a Field Termination Assembly (FTA) that is designed as a replacement for the TDC 3000 simplex analog input FTA. The FTA in conjunction with a MUX2700 will extract the digital HART data from standard 4-20mA loops. The HART Interface Solution interfaces up to 32 field located HART devices to a DCS and provides HART filters and allows for loop or device powered instruments.

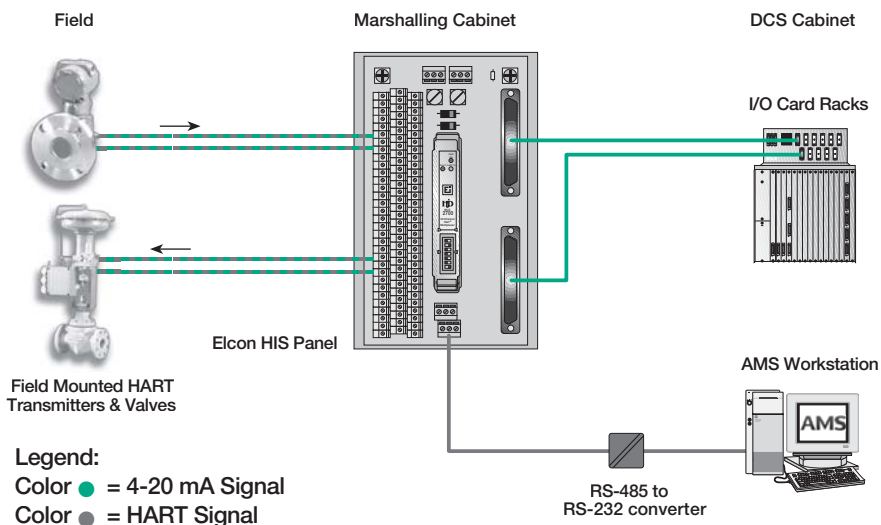

HPTB/32/HONB-AI-01

