

INSTRUCTION MANUAL
MODEL PS1550

FAULT TOLERANT POWER SUPPLY
For Mission Critical Applications

www.elconinstruments.com

Worldwide Headquarters

Pepperl+Fuchs GmbH • Königsberger Allee 87
68307 Mannheim - Germany
Tel. +49 621 776-0 • Fax +49 621 776-10 00
<http://www.pepperl-fuchs.com>
e-mail: info@de.pepperl-fuchs.com

USA Headquarters

Pepperl+Fuchs Inc. • 1600 Enterprise Parkway
Twinsburg, Ohio 44087 • Cleveland - USA
Tel. +330 425 35 55 • Fax +330 425 46 07

Asia Pacific Headquarters

Pepperl+Fuchs Pte Ltd • P+F Building
18 Ayer Rajah Crescent • Singapore 139942
Tel. +65 779 90 91 • Fax +65 873 16 37

Italy Headquarters

Pepperl+Fuchs Elcon
Via delle Industrie, 4 • 20050 Mezzago (MI) - Italy
Tel. +39 039 6292 1 • Fax +39 039 6292 240
e-mail: info@elconinst.com





INDEX

1.	INTRODUCTION	page	2
2.	UNPACKING	“	2
3.	STORAGE	“	2
4.	DESCRIPTION AND SPECIFICATIONS	“	3
	4.1 GENERAL INFORMATION	“	3
	4.2 OPERATIVE RANGE	“	3
	4.3 SPECIFICATIONS	“	4
	4.4 CONFIGURATIONS OF INPUT LINES	“	7
	4.5 INPUT LINE REQUISITES	“	8
	4.6 STRUCTURAL INFORMATION	“	9
5.	FUNCTIONAL DESCRIPTION	“	10
	5.1 GENERALITIES	“	10
	5.2 INPUT MODULE 1550/TB-IN	“	11
	5.3 OUTPUT MODULE 1550/TB-OUT	“	11
	5.4 LINE MODULE 1550/LM	“	11
	5.5 ALARMS	“	12
	5.6 1550/PM POWER MODULE	“	13
	5.7 CURRENT SHARING	“	14
	5.8 FAN MONITORING CIRCUIT BOARD	“	15
	5.9 MOTHER BOARD	“	15
	5.10 1550/RFD CHASSIS	“	15
6.	ELECTRICAL CONNECTIONS	“	17
	6.1 POWER CONNECTIONS	“	17
	6.2 INDICATION OF POWER FAILURE	“	18
	6.3 ALARM CONNECTION	“	18
	6.4 OUTPUT CONNECTIONS	“	18
7.	OPERATING INSTRUCTIONS	“	19
	7.1 PRELIMINARY CONTROLS AND CONNECTIONS	“	19
	7.2 ISOLATION TESTING	“	19
	7.3 STARTING UP	“	20
8.	MAINTENANCE	“	20
	8.1 SPARE PARTS	“	21
	8.2 REPAIRS	“	21
	8.3 TROUBLESHOOTING	“	22
9.	WARRANTY	“	24

WARNING!

This manual is copyright by Elcon Instruments. All rights reserved. No part of manual may be reproduced in part or in whole without express written consent from Elcon Instruments. Elcon Instruments reserves the right to modify manual or any part thereof at its discretion without prior notice.



1. INTRODUCTION

This manual serves to furnish adequate information for the installation, operation and maintenance of the PS-1550 Power System.

To avoid damage, breakdowns and improper utilization please read the manual carefully before attempting installation and utilization.

Furthermore, protect output and power lines from shortcircuiting considering that peak value and normal function of power delivered by this power unit is notable and capable of causing considerable damage if improperly utilized.

2. UNPACKING

Upon immediate reception of goods it is always advisable to check the integrity of the packaging and its contents. In case of damage due to transport, the receiver must immediately communicate entity and nature of damage by detailed report to carrier, furnishing all necessary information.

If the instrumentation is not destined for immediate utilization, it is always advisable to first control all characteristics reported on instrument labels against specifications reported in order (model, voltage and frequency, input/ output range, etc.) to assure that they are in conformance with real application requirements.

If not installed, the equipment should be stored according to the indications reported in the following paragraph: storage.

3. STORAGE

If storing instrumentation or accessories adequate precautions must be taken to protect them from damage. Keep instrumentation in sealed original package until installed. See that adequate protection is taken to prevent damage from exposure to:

- Rain, excessive humidity and/or thermal excursions (supply adequate shelter).
- Dust (formation of a corrosive layer that may cause oxidation and reduce insulation)
- Aggressive gases and pollutants (SO₂, H₂S, vapors, salts, flue gases, etc.) causing corrosion.
- Insects and rodents (damage to packaging and contents)
- Mechanical shock or non authorized opening of packaged product .
- Intense vibrations (loosening or detachment of fixed parts, breakage due to wear and tear, etc.)
- Any other possible risk.

Verify that warehouse or storage room temperature does not exceed limits -20°C and +60°C for middle to long term storage (days/months) and -25°C and +75°C for short term shipment or transport.

Upon completion of inspection, repack instrumentation in its original package, seal in plastic envelope together with Silica Gel, especially in damp environments. Itemize contents to avoid unnecessary further inspections.



4. DESCRIPTION AND SPECIFICATIONS

4.1 GENERAL INFORMATION

The PS1550 is a modular voltage power system devised to furnish 24V. Its characteristics make it particularly suitable for applications requiring flexible compact systems.

The PS1550 permits:

- Having dual power supply with redundant function and automatic detection due to voltage loss.
Output is guaranteed without variation in the following circumstances:
 - a) loss of one of the two voltage sources (the second automatically provides necessary power).
 - b) loss of a Line Module (the fault is automatically indicated by alarm relay and the second Line Module immediately supplies necessary power).
 - c) loss of one or more of the Power Modules (the remaining Power Modules automatically share the load – sharing current – and fault is indicated by alarm relay).

IMPORTANT: WHEN THE SYSTEM IS POWERED BY TWO LINES THEY MUST BE ISOLATED FROM EACH OTHER (THERE MUST NOT BE ANY POINTS IN COMMON) OTHERWISE AN ADEQUATE ISOLATION POWER TRANSFORMER MUST BE INSERTED IN SERIES ON ONE OF THE TWO MODULES.

- Hot plug-in Module insertion, including the fan box.
- Having a compact (19" for 4 stacked units) and powerful system (1 KW maximum output).
- Being able to choose maximum power output and minimizing available space thanks to its modular construction.
- Having an efficient system (typical yield 80%) with minimum heat dissipation.

Moreover the system:

- Limits the inrush current value during the first start up (by NTC at 15Ω 2W).
- Is protected against power surges (by a varistor with energy absorption of 71 Joules in 2 ms).
- Is protected against shortcircuiting at output (pushbutton function).
- Is thermally protected (each Power Module has its own thermal protection of 85 °C).

The power supply system is mounted 4 units high on a 19" modular rack (1550/RFD) and cooled by forced ventilation (three 100 m³/h fans are incorporated).

The chassis accepts a 1550/TB-IN Input Module, a 1550/TB-OUT Output Module, two (to obtain redundancy) 1550/LM Line Modules and one or more (up to six with current sharing) Power Modules (max. 7A each).

4.2 OPERATIVE RANGE

The PS1550 power system is capable of generating elevated power (up to approximately 1KW) with high efficiency (about 80%) in a reduced space.

Notwithstanding the efficiency of the system, a substantial quantity of power (approximately 210 W with a nominal load of 36A) is dissipated in the form of heat which must be eliminated in order to maintain the temperature within acceptable limits.

The device consents considerable cooling by natural convection thanks to the large finned dissipators mounted on the Power Modules. This solution permits function without forced ventilation and the operative area (characteristic Voltage output/ ambient Temperature) is displayed in figure 1.

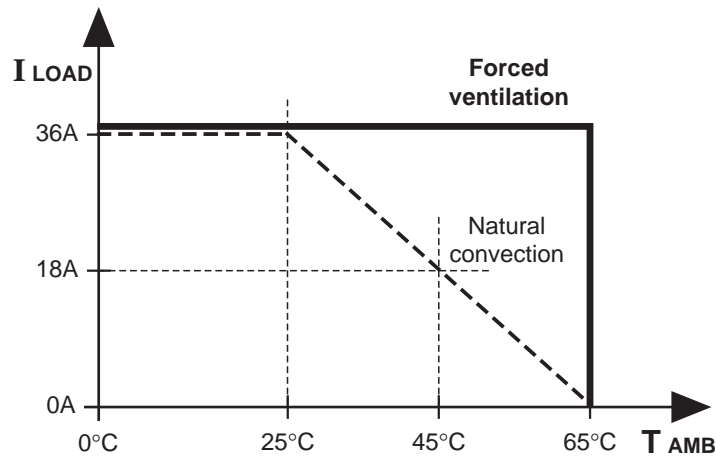

Fig. 1. Operative area of PS1550 system.

The Power Modules are thermally protected. If temperature exceeds 85 °C at 'baseplate', the Modules deactivate until correct operative conditions are restored. Such conditions set off alarm relay.

The chassis is fitted with 3 fans, 100 m³/h each for a total air flow of 300 m³/h. These values permit the system to function at maximum power up to an ambient temperature of 50 °C while with nominal load the curve is that reported in figure 1. The fans are housed in the lower part of the chassis and are all mounted on a sliding box; they can be removed easily by extraction via the hinged panel situated at lower front side. When the panel is opened, a microswitch interrupts power supply to fans permitting easy access without risk.

If one of the fans breaks down, the corresponding green LED function indicator is set OFF and the alarm relay is activated.

4.3 SPECIFICATIONS

INPUT

- Input voltage (Line 1 and/or Line 2)

- AC: 230 Vac nominal $\pm 15\%$ (195 ÷ 264 Vac) at 47 ÷ 63 Hz.
- AC: 115 Vac nominal $\pm 15\%$ (97.5 ÷ 132 Vac) at 47 ÷ 63 Hz.
- DC: 130 Vdc nominal (100 ÷ 180 Vdc).

- PS1550 Versions

Two versions of the system have been foreseen:

- Type-230: version with alternating input voltage both at 230 Vac.
- Type-115: version with input voltage at 115 Vac and/or 130 Vdc.

- Input current in stationary conditions and nominal (rated) load (36 A)

- AC 230 Vac: 6.6 A rms (17.0 A peak).
- AC 115 Vac: 12.1 A rms (25.5 A peak).
- DC 130 Vdc: 9.0 A.



- **Input current in stationary conditions and maximum load (1 KW)**
 - AC 230 Vac: 7.4 A rms (19.3 A peak).
 - AC 115 Vac: 13.3 A rms (28.0 A peak).
 - DC 130 Vdc: 10.1 A.

- **Inrush current**
 - AC 230 Vac: the inrush current value for the first start up is 35 A for each Line Module.
 - AC 115 Vac: the inrush current value for the first start up is 18 A for each Line Module.
 - DC 130 Vdc: the peak current for the first start up is 13 A.

- **Crest factor**
 - AC 230 Vac: the ratio between peak value and effective voltage input is 2.6.
 - AC 115 Vac: the ratio between peak value and effective voltage input is 2.1.

- **Switching from Line 1 to Line 2 and vice versa (with two line Modules inserted)**

If one of the two power sources fails, switch over from one Line to the other is automatic and instantaneous.

- **Under voltage Signal**

The alarm relay commutes if line voltage is less than 75% of nominal value.

- **Turn-on Time**

The time lapse between the application of line voltage and the instant in which output is stabilized is at maximum 300 ms.

OUTPUT

- **Voltage**

Each Power Module provides a voltage of 24.7 V \pm 10%, adjustable by rotating trimmer accessible on front panel of 1550-PM Modules. Voltage can be read via test points situated on panel front (refers to the readout upstream from the decoupling diode present at outlet of each Module).

- **Ripple**

Output ripple is 100 mVpp at nominal load (36 A).

- **Current**
 - *Nominal Current*: each Power Module delivers 6 A nominal (the current can be read via test points situated on panel front: 100 mV correspond to 1 A output).
 - *Current alarm*: each Power Module delivers up to 7 A before signalling alarm via relay.
 - *Current overload*: each Power Module can deliver up to 7.5 A before limiting voltage. At 20.5 V output, the current is about 8 A.
 - *Shortcircuiting*: in overload conditions the output voltage starts pulsing when below 9 V; if after such conditions a nominal load is applied (36 A), output reaches 24 V with maximum delay of 1.3 seconds.

- **Output terminals**
 - Output Module type 1550/TB-OUT: out with 16+16 2.5 mm² terminal blocks, up to 4 Amperes each.
 - Output Module type 1550/TB-OUT 4/20: out with 4+4 6 mm² terminal blocks, up to 16 Amperes each.
 - Output Module type 1550/TB-OUT 60: out with 1+1 terminal blocks, up to 60 Amperes each.

**- Line regulation**

Varying line voltage from minimum to maximum value and working at nominal load, output varies less than 50 mV.

- Load regulation

Varying current output from 0 to 36 A, output varies less than 500 mV.

- Undervoltage alarm

The alarm relay is activated when voltage output is less than 20.5 V \pm 0.5 V.

- Short Power Mains Interruption

- AC 230 Vac: with mains voltage at minimum (195 Vac) and nominal load of 36 A, the time interval between power loss and the instant the output voltage starts to drop, is greater than 15 ms.

- AC 115 Vac: with mains voltage at minimum (97 Vac) and nominal load of 36 A, the time interval between power loss and the instant the output voltage starts to drop, is greater than 15 ms.

- AC 130 Vdc: with mains voltage at minimum (100 Vdc) and nominal load of 36 A, the time interval between power loss and the instant the output voltage starts to drop, is greater than 10 ms.

ALARM RELAY CHARACTERISTICS

250 Vac / 2 Amp / 100 VA

125 Vdc / 2 Amp / 50 W

INTERNAL FUSES**- Line Module**

- F1: resistance 2.2 Ω 1/2 W.

- F2, F3: T 10A 250/500V 6.3x32 for type-230 or T 20A 250/500V 6.3x32 for type-115.

- Power Module

F1: T 3.15A 500V 6.3x32 for type-230 or T 5A 250/500V 6.3x32 for type-115.

- Fan power supply

F1, F2, F3: T 0.5 A 250V 5x20.

INSULATION

- Inputs/Ground: 2500 Vac per 1 minute.

- Inputs/Output: 2500 Vac per 1 minute.

- Output/Ground: 500 Vdc per 1 minute.

REFERENCE NORMS

The PS1550 power system conforms to the following norms:

- EN 50081-2

- EN 50082-2

- EN 60950



4.4 CONFIGURATION OF INPUT LINES

The PS1550 system equipped with two Line Modules can be powered by two separate voltages (Line1 and Line 2) and its particular type of redundancy permits dealing with the loss of one of the lines without affecting output..

The possibility of having an alternating or continuous current , makes the system highly flexible leaving the user the possibility of selecting the best strategy to employ.

Various cases are possible:

A) ONE ALTERNATING CURRENT INPUT

In order to have a reliable system the power line must be furnished with a UPS unit to guarantee redundancy of line Modules, Line1 and Line 2 must be connected in parallel to mains.

B) TWO STANDARD ALTERNATING CURRENT INPUTS

This is a low cost solution and is very easy to carry out: it simply requires connecting two power lines; so that if one line fails, the second automatically fulfills all power requirements.

The two power lines must originate from two separate power sources so that if one fails it does not provoke the additional consequent loss of the other.

If the probability and duration of one line loss is low for both inputs, it is easy to assume that the contemporaneous loss of both inputs would be an improbable event and therefore system reliability is at any rate guaranteed.

C) STANDARD ALTERNATING CURRENT AND EMERGENCY ALTERNATING CURRENT (OR UPS) INPUT

This solution utilizes standard alternating current as well as an emergency power source (it must be activated within 10ms from the loss of the power line or must be an uninterruptible type –UPS-). In order to avoid having the UPS line under permanent charge, its voltage output must always remain slightly below (a few volts) that of the main line so that it does not supply current under normal conditions.

This set up is more costly than A) due to the fact that it has a truly independent source, but is certainly more practical and safe.

If the line is not a UPS type, make sure that maximum intervention time does not exceed 10 ms in order to avoid 'glitches' or transitory output losses.

D) STANDARD ALTERNATING CURRENT (115 Vac) AND DIRECT CURRENT BUFFER (BATTERY at 110 Vdc)

This solution utilizes standard alternating current at 115 Vac which normally powers the system, and an emergency direct current system (system with buffer battery at 110 Vdc) which intervenes in case of loss of main line.

This set up is cheaper than B) and offers equal or even more reliability.

The battery system must be such as to permit 24 V output for at least 20 minutes for maximum power (20 minutes is generally an acceptable time to carry out emergency procedures).

In all cases analyzed the loss of one line is signaled via alarm relay mounted on respective line Module.



4.5 INPUT LINE REQUISITES

Line1 and Line 2 must respect the following requisites:

LINE INSULATION

WHEN THE PS1550 SYSTEM IS POWERED BY TWO LINES, THE LINES MUST BE ISOLATED FROM EACH OTHER IN ORDER TO AVOID POTENTIALLY HAZARDOUS CONNECTIONS BETWEEN THE TWO DUE TO A COMMON CONNECTION TO NEUTRAL. THIS AVOIDS THE APPARANCE IN THE RECTIFICATION SYSTEM OF A COMBINATION OF INPUT VOLTAGES SUPERIOR TO BOTH VALUES: THE CAUSE IS A PHASE DISPLACEMENT BETWEEN THE TWO (FOR A PHASE DISPLACEMENT OF 180° THE SUM OF THE TWO LINES APPEARS!). NOTE THAT UPS SYSTEMS VARY THEIR PHASES IN ORDER TO LINK ON TO MAIN LINE FREQUENCY.

VOLTAGE

- *Type-230*: 230 Vac nominal \pm 15% (195 ÷ 264 Vac), 47 ÷ 63 Hz, 10% T.H.D. maximum.
- *Type-115*: 115 Vac nominal \pm 15% (97.5 ÷ 132 Vac), 47 ÷ 63 Hz, 10% T.H.D. maximum 130 Vdc nominal (100 ÷ 180 Vdc).

SHORT POWER MAINS INTERRUPTION

Power input must not lack for more than 10 mseconds to avoid the appearance of 'glitches' or transitory output loss.

INRUSH CURRENT

- AC 230 Vac: to be able to guarantee each line Module an inrush current value of 40 A during first start up.
- AC 115 Vac: to be able to guarantee each line Module an inrush current value of 20 A during first start up.
- AC 130 Vdc: to be able to guarantee each line Module a 16 A voltage peak during first start up.

CREST FACTOR

- AC 230 Vac: the ratio between peak value and effective value of voltage must be 3.
- AC 115 Vac: the ratio between peak value and effective value of voltage must be 2.5.

VOLTAGE IN STATIONARY CONDITIONS AND MAXIMUM LOAD (1 KW)

- AC 230 Vac: 8 A rms (21 A peak)
- AC 115 Vac: 14 A rms (30 A peak)
- DC 130 Vdc: 12 A

PROTECTION AGAINST SURGES

The power lines must have some form of protection against transitory phenomena that may result hazardous. Protection against surges permits limiting voltage spikes which may be generated in the following cases:

- A short circuit along the power line generates the sudden passage of very high voltage. Repeated interruption of this nature on the part of the fuses creates a high energy voltage spike throughout the entire system with consequent risks to the whole system.
- Opening an inductive load generates a high energy voltage spike thus submitting the entire system to notable stress.
- A very short power interruption may create mains voltage spikes due to coupling with consequent system stress.

The PS1550 is protected against interference and transitory phenomena by the implementation of a suitable filter at input and varistor with energy absorption of 71 Joules in 2 ms.



4.6 STRUCTURAL INFORMATION

The PS1550 power system consists of:

A) a chassis:

1550/RFD A 19" rack predisposed to accept 4 stacked units including extractable fan box.

B) an Input Module:

1550/TB-IN is the terminal module for power inputs (230 Vac, 115 Vac, 130 Vdc) also including the terminal board for alarm relay contacts.

C) an Output Module; three different versions exist (figure 2):

1550/TB-OUT is the standard output module with 16+16 terminals suitable for connections up to 4 Amperes each.

1550/TB-OUT 4/20 is an optional output module with 4+4 terminals suitable for connections up to 16 Amperes each.

1550/TB-OUT 60 is an optional output module with 1+1 terminals suitable for per a single maximum power connection, (~60 A).

D) two redundancy line Modules which must of the same version; based on the type of system (type-230 or type-115) there are two possibilities:

1550/LM-230 is the module that permits working with 230 Vac input voltage.

1550/LM-115 is the module that permits working with 115 Vac or 130 Vdc input voltage.

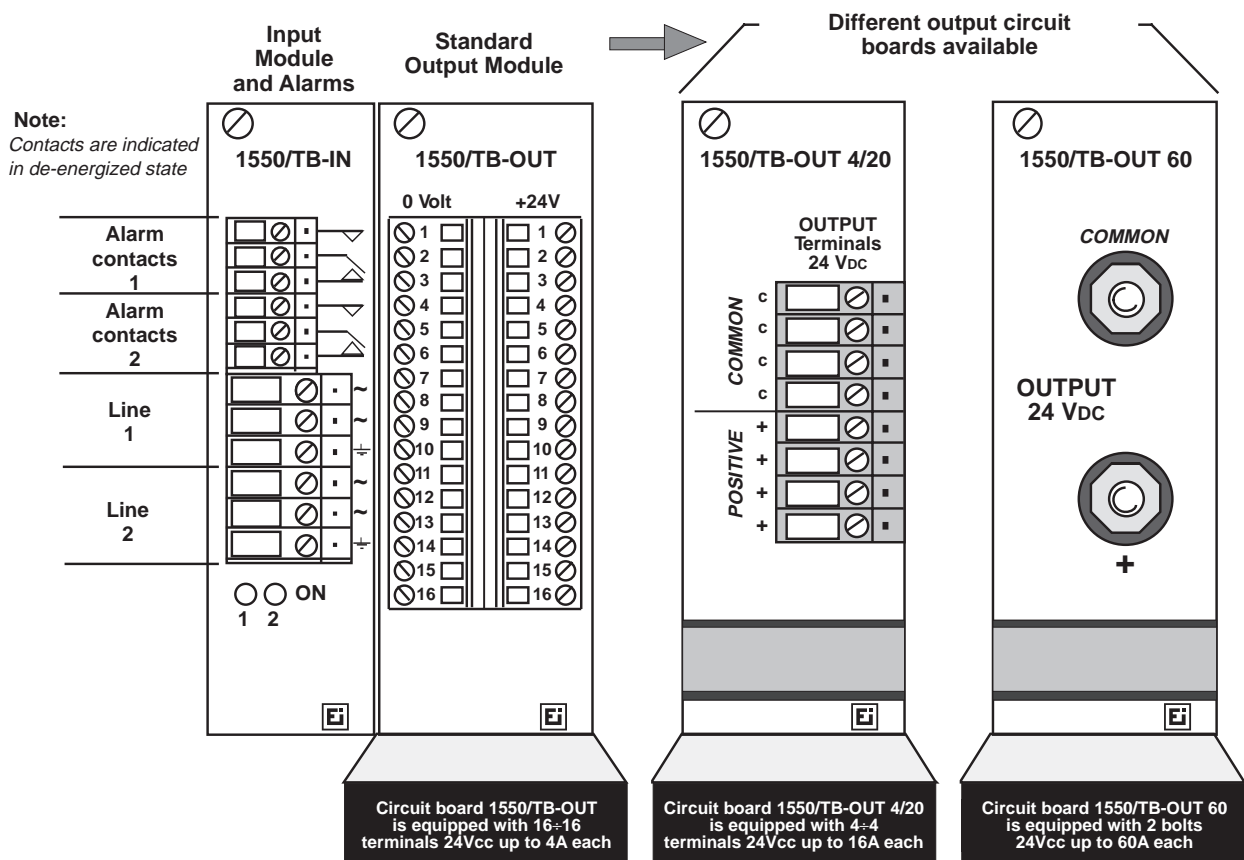

Fig. 2. Input module and three versions for Output Modules



- E) from one to six Power Modules which must be all of the same version; based on the type of system there are two possibilities:
 1550/PM-230 is the module that implements conversion for coupling with system type-230.
 1550/PM-115 is the module that implements conversion for coupling with system type-115.

5. FUNCTIONAL DESCRIPTION

5.1 GENERALITIES

The PS1550 is a continuous voltage power system providing 24V and maximum 1kW power. It has been constructed modularly and operates in switching mode to maximize conversion efficiency. Two separate power lines, 230 Vac or 115 Vac, have been foreseen in addition to a 130 Vdc line. They are redundant, therefore failure of one of the two has no effect on output which remains unaltered.

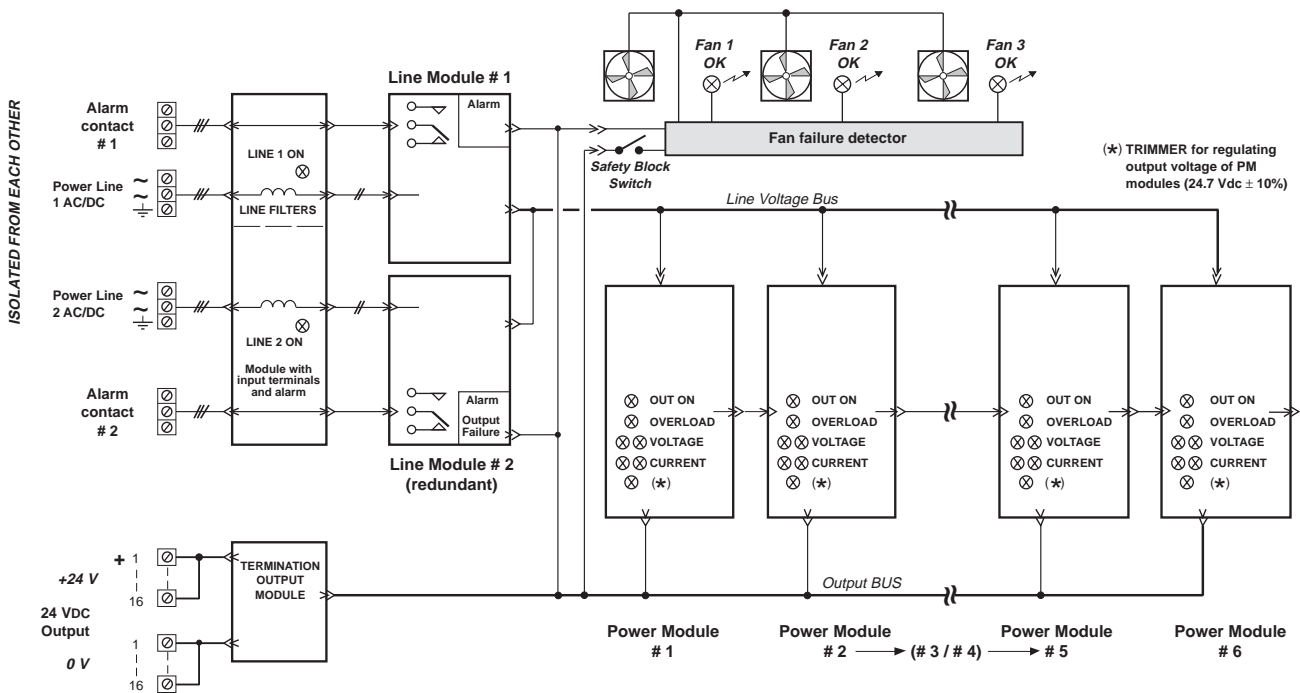

(*) IMPORTANT !
 WHEN TWO POWER LINES ARE UTILIZED, LINE 1 MUST BE ISOLATED FROM LINE 2 (NO COMMON POINTS)
 OTHERWISE A POWER ISOLATION TRANSFORMER IS NECESSARY ON ONE OF THE TWO LINES.

Fig. 3. Block diagram of PS1550 system.

The conversion is carried out by six Power Modules through the utilization of six LAMBDA PH150S-280-24 or PH150S-110-24 components according to the type of system. The six Modules are independent and can be extracted and inserted (hot plug-in insertion/extraction) in the rack even when the system is under tension. They function in parallel thanks to the implementation of a sharing circuit which guarantees that they all work at the same voltage. The failure of one Power Module does not compromise the system but only implies a reduction of maximum voltage output.



Two low voltage contact alarm relays are associated with the power lines which signal the presence of ongoing anomalies in case of:

- input undervoltage
- output undervoltage
- Power Module undervoltage
- Power Module overload
- Power Module failure
- ventilation system failure

These events are monitored by a POWER GOOD signal which are common to all system modules via the Mother Board.

5.2 INPUT MODULE 1550/TB-IN

This is the Module through which the system is powered: the presence of the two lines is indicated by respective LEDs. The Module provides an initial filtering of the first emissions conducted across Module by way of two mains filters.

The terminal board mounted on Module gives access to alarm relay contacts (stenciling indicates type of connection).

5.3 OUTPUT MODULE 1550/TB-OUT

The power connection output terminal boards are mounted on Module; as previously described there are three possible versions.

5.4 LINE MODULE 1550/LM

According to version, the modules have been predisposed for function at 115 Vac / 130 Vdc or 230 Vac.

The 1550/LM circuit consists of an internal line rectifier with capacitive filter and decoupling diode. The inputs are protected by two time-lag fuses (10 A or 20 A respectively based on type of system) . The voltage once rectified is made available to Power Modules via Mother Board bus +IN / -IN.

The overall value of the bank of capacitors is enough to guarantee in case of mains failure, an interim 15ms output time (both for type-230 and type-115) with nominal voltage load (36A).

The line Modules present a green LED on panel front which lights up when the mains has reached the correct value for system function. A special circuit with the utilization of a TL431 measures input voltage and gives the go ahead signal (LED on and alarm relay pick-up current- energize) when 75 % of nominal value has been reached. An implemented hysteresis value for which the LED is set OFF occurs due to inferior voltage value.

Inrush current is limited by a NTC (15 Ω or 10 Ω based on type of system) placed in series with the line that is shortcircuited by relay contacts RL2 and RL3 after the system has been started.

A 24 V auxiliary current is thus generated in the Module which serves the control circuitry and inrush current relays. The integrated circuit TOP 223Y is utilized for this purpose: a high voltage channel N MOSFET and a 100 KHz oscillator for voltage control PWM function have been implemented in it. This component is powered via the control pin C which is normally at 5.7 V.

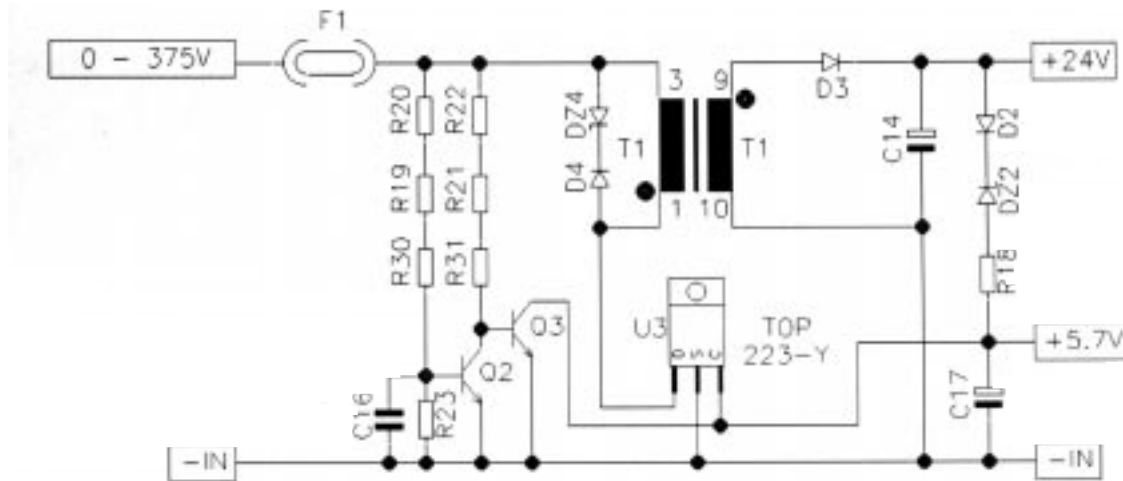

Fig. 4. Auxiliary power supply in line Modules.

The TOP 223Y is a non isolated simple flyback converter. With reference to figure 4, D4 and DZ4 reduce spikes on Drain, D3 and C14 rectify and filter voltage output from transformer, while the 24V are controlled by DZ2; D2 prevents loading pin C at start up. C17 carries out more functions: it determines a components starting time, determines restarting frequency during shortcircuiting, filters the signal to control pin and compensates system. The auxiliary circuitry including the two transistors Q2 and Q3, avoids any uncertainty during activation and deactivation of TOP223Y: activating circuit occurs with power supply (voltage at the test capacitors) above $65V \pm 10\%$, while deactivation occurs due to voltage below $55V \pm 10\%$.

The PS1550 is provided with two redundant line Modules so that in case of power failure concerning one of the two power lines or modules, output is at any rate guaranteed by the presence of the second line. This result is possible thanks to the block diode on 1550/LM output.

5.5 ALARMS

Alarm relays and relative command circuit are mounted in line Modules. They are 24V relays with output contacts suitable for low voltage connections. They are commuted according to POWER GOOD signal level: normally they are activated and only de-energize due to system failure (POWER GOOD passes from high to low state). The variation of the signal may occur for one or more reasons; various alarm causes are reported in the following.

• Input Undervoltage

The green LED indicator of line Module is on and the alarm relay is activated when values are above:

- 178 Vac $\pm 3\%$ when mains is 230 Vac
- 93 Vac $\pm 3\%$ when mains is 115 Vac
- 95 Vdc $\pm 3\%$ when mains is 130 Vdc

The alarm relay de-energizes and the line Module green LED indicator is set OFF when at nominal load the respective voltage goes below:

- 172 Vac $\pm 3\%$ when mains is 230 Vac
- 90 Vac $\pm 3\%$ when mains is 115 Vac
- 92 Vdc $\pm 3\%$ when mains is 130 Vdc



- **Bus Output Undervoltage**

The alarm relays de-energize due to lack of output in as much as they rely on output .

- **Undervoltage of one of the Power Modules**

The alarm relays de-energize and respective green LED indicator of Power Module is set OFF, when voltage output goes below 20.5 ± 0.5 Volts.

- **Overload of one of the Power Modules**

The alarm relays de-energize and respective red LED indicator of Power Module is set ON, when voltage output from Module is above 7 A.

- **Failure of one of the Power Modules**

The alarm relays de-energize when one of the Power Modules fails and in particular if component PH150S-280-24 (respectively PH150S-110-24) does not furnish output.

- **Malfunction of one of the cooling fans**

The relays de-energize and the green LED indicator of respective fan is set OFF, when the voltage absorbed by fan exceeds the interval between 120 mA - 420 mA.

The contacts of the two alarm relays can be easily connected to each other in order to obtain a particular result (for example connecting the two normally open contacts in parallel it is possible to create an alarm circuit in which whichever of the two relays signalling system anomaly has no importance).

(For connections see chapter 6.3).

5.6 1550/PM POWER MODULE

As many as six power modules can be housed in the PS1550 system, any unused slot can be covered by panel.

Each Power Module consists of an insulated DC/DC converter, which functions in switching mode at a frequency of 330 KHz. LAMBDA PH150S-280-24 for type-230 and LAMBDA PH150S-110-24 for type-115 components are utilized: they convert the rectified power supply current present in bus +IN / -IN, into 24 V voltage output.

A filtering stage is present at input of all Power Modules which permits the reduction of conducted emissions.

The bus output connection is carried out by a low drop diode which acts as an insulator in case of breakdown or failure.

Each of the Modules is sized (for reasons of heat dissipation and reliability) to deliver up to 6A nominal but can also furnish up to 7 A before creating an alarm situation (it is possible to set this threshold via trimmer RV2, factory set). When overloaded the current is limited to about 8 A.

There are four test points on front panel which permit current and voltage output readout of specific Module: these points present an output resistance of 1 K Ω .

The measure of current at test points is greater than that measured in Module output due to drop in decoupling diode (typically 0.4 V).

To get a readout of current furnished by Module via dedicated test points, utilize predisposed tester as a continuous voltmeter ; every 100 mV detected correspond to 1A of delivered voltage (for example 560 mV correspond to 5.6 A). The measurement signal is obtained simply by amplifying by LM 385 the voltage drop in shunt.

The auxiliary circuitry mounted in Power Module permits:

1. Implementing current sharing between various Power Modules.

2. Detection and indication via red LED (on) indicator on front panel, voltage overload (Module current above 7 A set with RV2).
3. Detection and indication via green LED (OFF) indicator on front panel, undervoltage (Module voltage output less than 20.5 ± 0.5 V).

The indication of events 2 and 3 is carried out by lowering POWER GOOD signal, this provokes de-energizing of alarm relay. To produce this result two comparators are utilized; the reference is obtained with the auxiliary of a TL431 which furnishes 2.5 V with 5% accuracy.

If component PH150S-280-24 (PH150S-110-24) does not provide voltage output, the POWER GOOD

5.7 CURRENT SHARING

The technique utilized is reported in figure 5: current furnished by Power Modules is compared and their reference voltage modified so that they are induced to function in the same way.

In reference to figure 5, amplifier A amplifies signal detected in shunt (to within 3%) and its output pin reaches 5 V when current from Module is equal to 6 A. The signal obtained in this manner is then sent to common SHARING bus via unidirectional buffer (labeled B). The highest SHARING current is thus presented at B, for which, if the Module in question furnishes low current to others, a difference is created at input pins of amplifier C. Such a condition generates a drop of output at C therefore an increase in current (and as a consequence, of voltage) delivered by Power Module.

In balanced conditions no differences exist at input C and at pin output is measured at 2.5 V. Current sharing is only permitted if Module current output results unbalanced in respect to balanced state, and falls in the range of $\pm 2.5\%$ (± 0.6 V).

As can be noticed, the sharing system only functions in one direction due to the fact that only the Modules that furnish less current have to adjust.

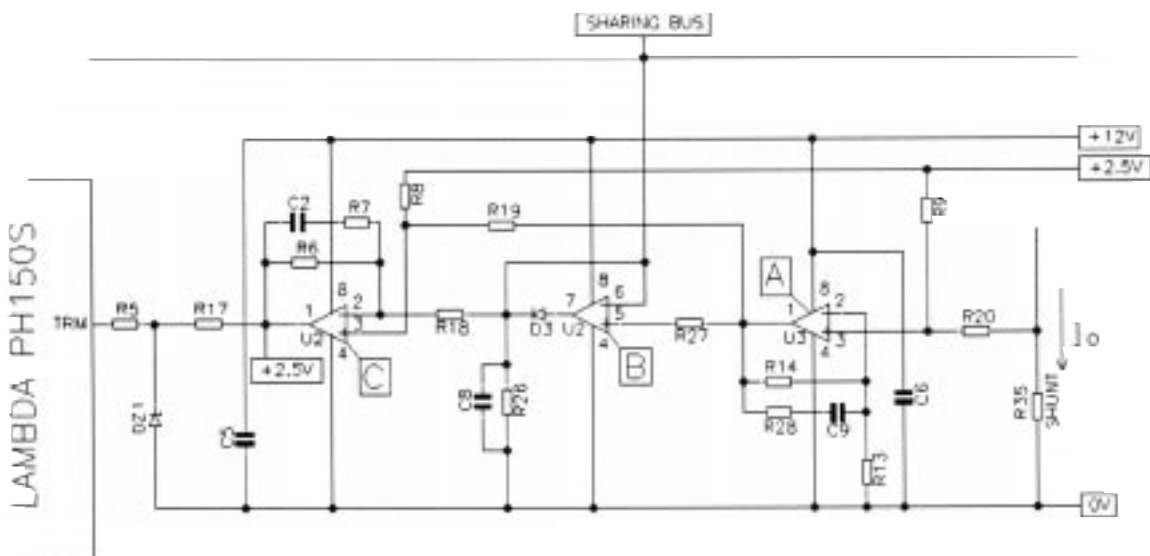

Fig. 5. Current Sharing circuit mounted in Power Modules.



5.8 FAN MONITORING CIRCUIT BOARD

This circuit board manages the monitoring of the three fans mounted on the PS1550. Their correct function is indicated when powered, by the three green LED indicators situated on panel. If voltage absorbed by one of the fans is outside the interval between 120 mA - 420 mA (therefore indicating interruption or overload) the respective LED is set OFF and the POWER GOOD signal lowered (stepped-down) so that alarm relays de-energize. Failure or malfunction is signalled by a 3 second delay.

A power cut-off switch is mounted on the circuit board which interrupts power delivery to fans when panel is opened: even when panel is open, and therefore fans inoperative, the signal is relayed to alarm relay.

5.9 MOTHER BOARD

The mother board permits the system to function modularly: in it there are all the power buses (input current, rectified current for powering Power Modules, output voltage) and signal buses (SHARING, POWER GOOD, alarm relay contacts).

5.10 1550/RFD CHASSIS

A diagram of the chassis is reported in the following figures. As can be seen it permits housing a maximum of 10 Modules.

For the system to be mounted in a cabinet, a 19" slot must be predisposed for its insertion (figure 6).

To panel mount (front panel), preparation of housing must be predisposed as per cut-out in figure 8, then insert rack in front panel and fasten by 4 threaded screws.

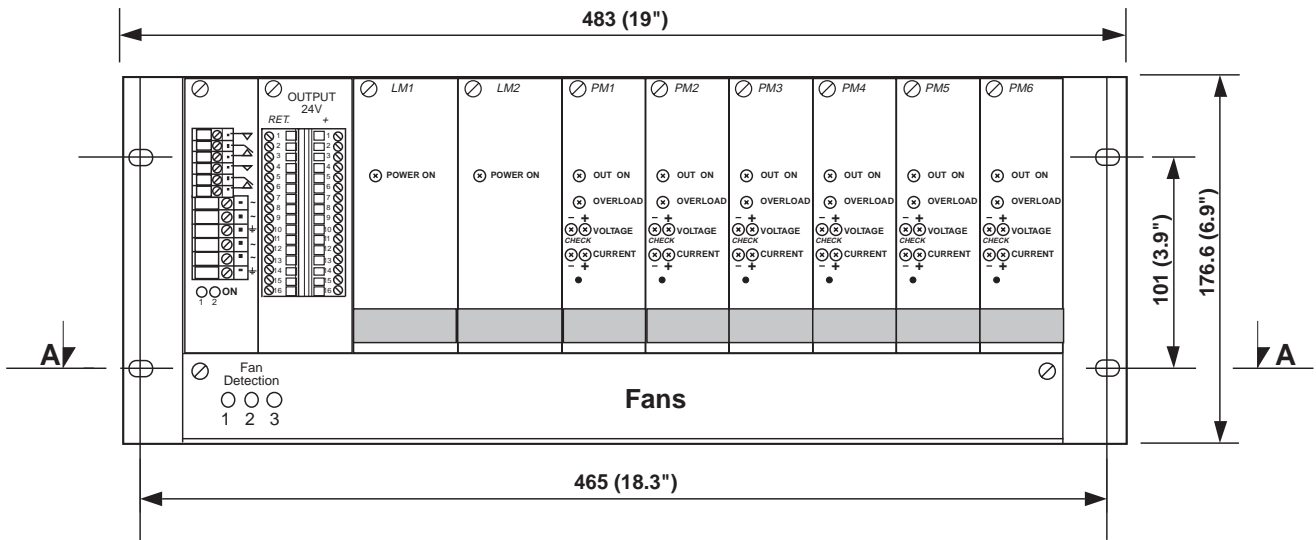

Fig. 6. Front view of PS1550 system.

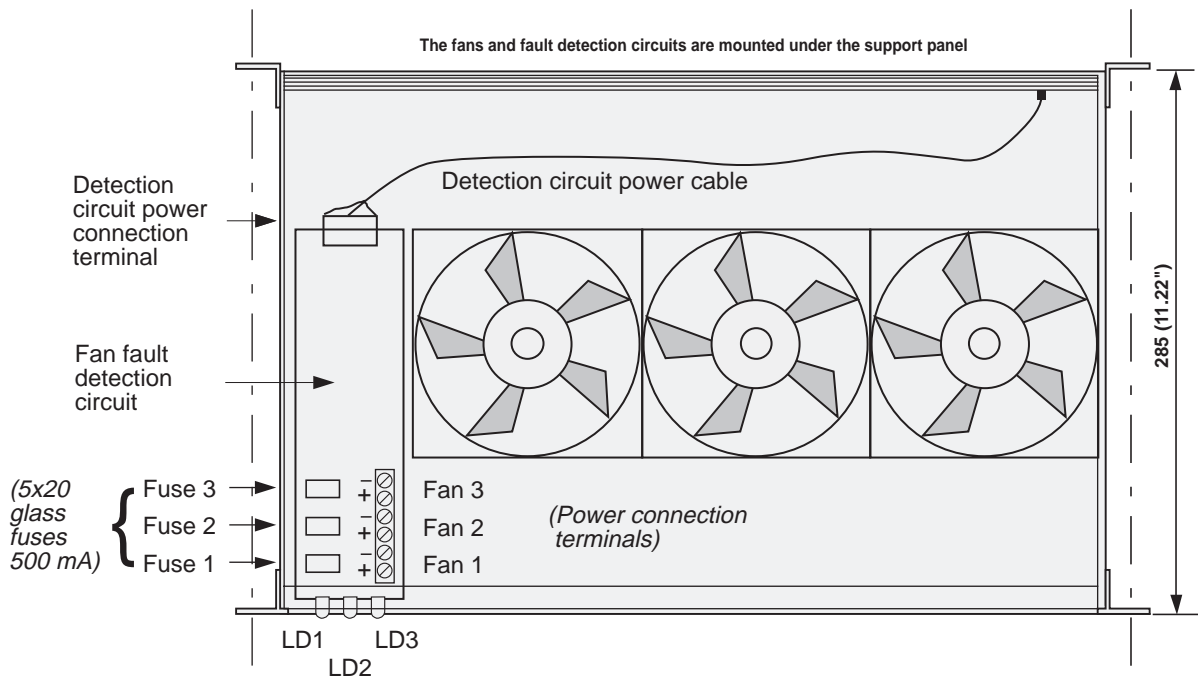

Fig. 7. Fan box (Section A-A of figure 6).

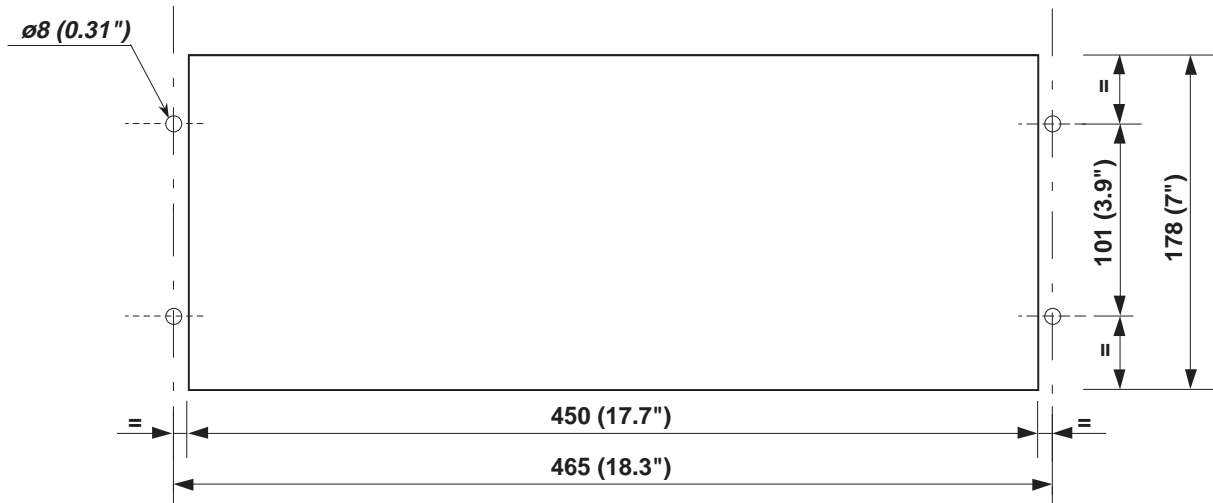

Fig. 8. CUT OUT (for mounting panel).



6. ELECTRICAL CONNECTIONS

6.1 POWER CONNECTIONS

WARNING!

Potentially lethal voltage up to 400V is generated by some parts of this power supply system. Do not remove any protective covering or access while in function.

All modules are plug in cards that can be individually repaired without having to open the chassis! Improper connection of power supply line may cause serious damage to power supply system and associated equipment.

Verify grounding connections to avoid risk of electrical shock.

As previously mentioned in section 4.4 there are three possible specific power configurations:

- Dual power supply by standard AC mains
- Standard AC mains and emergency AC (UPS)
- Standard mains (115V) and auxiliary power supply by battery (110V)

Connect power supply lines to terminal blocks as shown in Fig. 2 on page 9 utilizing 4mm² wire. Consult chapter 4.4 for further details concerning configuration of power supply system.

Make sure that mains wires are properly connected (phase or positive, neutral or negative and ground).

Verify that wiring is fastened solidly to terminals in order to avoid intermittent connections or hazardous electrical arcs! Verify that no part(s) of wiring is exposed or can cause shortcircuiting with ground or other wires.

Install adequately sized switches (8 Amp for function at 230V, 16 Amp for function at 115V) on each power line in readily identifiable positions and which can be easily accessed in case of emergency (i.e. repairs).

If two power lines are connected make sure that two line modules are inserted in rack.

ISOLATION OF POWER LINES

IMPORTANT!

WHEN A PS-1550 MODULE IS UTILIZED IN CONJUNCTION WITH TWO POWER LINES THEY MUST BE ISOLATED FROM EACH OTHER IN ORDER TO CARRY OUT AN INTERCONNECTION OF LINES EXTERNAL TO POWER SOURCE. (i.e. THROUGH COMMON NEUTRAL CONNECTION).

THIS AVOIDS THE APPEARANCE OF A COMBINED HIGHER VOLTAGE IN RESPECT TO LINE VOLTAGE IN POWER SUPPLY SYSTEM RECTIFIER AS A FUNCTION OF RESPECTIVE PHASE DISPLACEMENT (FOR PHASE DISPLACEMENT OF 180° THE SUM OF THE TWO VOLTAGE LINES IS VERIFIED!).

NOTE THAT THE MAJORITY OF UPS IN BACKUP

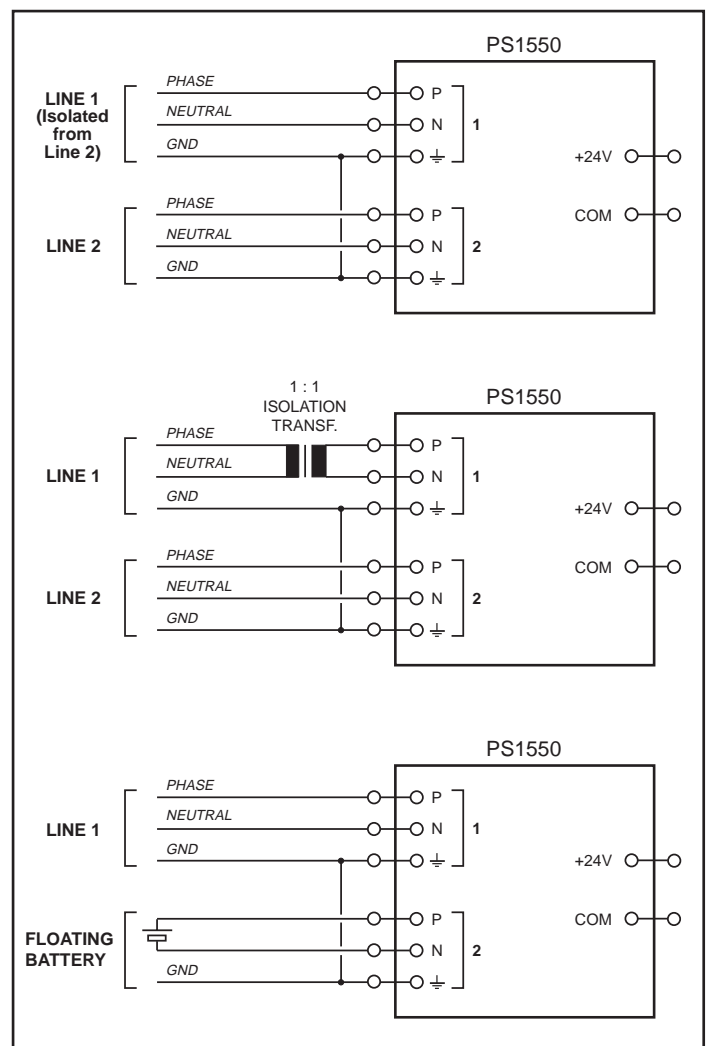

Fig. 9. Inputs connection.



PHASE, WHILE TRACING MAINS FREQUENCY, VARY THEIR PHASES UNTIL FREQUENCY IS COUPLED.

WHEN IN DOUBT ABOUT LINE ISOLATION, UTILIZE AN ISOLATION TRANSFORMER 1:1 ON ONE OF THE TWO LINES (WHICHEVER IS PREFERABLE).

TRANSFORMER CHARACTERISTICS MUST BE CHOSEN ON THE BASIS OF REQUESTED POWER INPUT WHICH IS ABOUT 1.4 TIMES THAT OF POWER OUTPUT FROM POWER SUPPLY.

(i.e. OUTPUT

$40A/24V = 960 \text{ WATT}$,

$960/1.4 = 1300 \text{ VA approximately}$)

A SINGLE ISOLATION TRANSFORMER, IF SUITABLY SIZED TO POWER, CAN BE UTILIZED FOR MORE THAN ONE POWER SUPPLY.

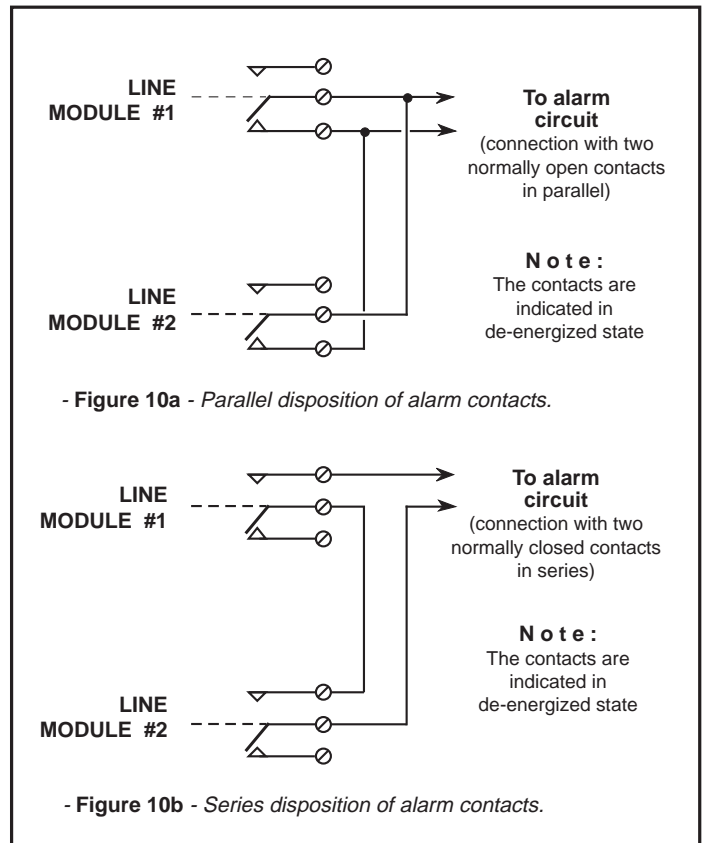

6.2 INDICATION OF POWER FAILURE

Each line Module has a normally energized relay, which activates alarm due to lack of power supply (power failure) via relative terminals (second example in figure 10). This permits rapid notification of malfunction and the reestablishment of normal operative conditions.

6.3 ALARM CONNECTIONS

For installation where alarms are actuated subsequent to opening of contacts, connect the two normally closed contacts in series on input module (1550/TB-IN) (see Fig. 10b).

In this manner, without alarm situation, the contact remains closed and any alarm will open the series.

Otherwise if alarm utilizes for activation, contact closure, the two normally open contacts can be connected in parallel so that without alarm they remain open and any alarm situation will close circuit. (see Fig. 10a). The alarm contacts characteristics are: 250Vac/2Amp/100VA ; 125Vdc/2Amp/50W.

6.4 OUTPUT CONNECTIONS

Connect the output to terminals on front panel (see Fig. 2 on Pag. 9).

For the output card model 1550/TB-OUT all 16 positive terminals are connected together via bus in analogous manner to the 16 negative terminals (return).

Each terminal can take up to 4 Amp. Maximum wire 2.5mm^2 .

The 16 terminals permit a power distribution of 24V to 16 different positions within the cabinet without requiring piggy-back connections, maintaining line voltage drop to within negligible limits. As an option the PS-1550 can be furnished with Mod. 1550 TB-OUT 4/20 output module with 4+4 terminal block capable of handling 16 Amp each, or with Mod. 1550 TB-OUT 60 module with 1+1 terminals that can handle up to 60 Amp each.

(See relative drawings in Fig. 2).



7. OPERATING INSTRUCTIONS

7.1 PRELIMINARY CONTROLS AND CONNECTIONS

Before starting the PS1550 power system the following must be verified:

INPUT LINES

- A. Input line voltage must be correct and in accordance with specified nominal value on panel front of Modules 1550/TB-IN (first on left) and 1550/LM (third and fourth from left).
- B. Wiring utilized for input lines must be of adequate sizing (in accordance with maximum requested voltage) and must be firmly connected to respective terminals without any exposed parts that may cause shortcircuiting (Phase, Neutral and Ground or Positive, Negative and Ground) or potential hazards for user .
- C. Power lines must be fitted with automatic protection switches which remain readily and easily accessible to user.
- D. **Important:** when the system is powered by two lines, the lines must be isolated from each other (no common points) or an isolation transformer must be inserted in series suitable for one of the two lines (see fig. 9).
- E. If one of the two currents is continuous, the Positive terminal must be connected to the first terminal above, relative to the chosen section (Line 1 or Line 2).

OUTPUTS

- A. Make sure that polarity of output connections is correct (positive output must be connected to positive load and this is also true for all other loads).
- B. Wiring utilized for output connections must be adequately sized (in accordance with maximum voltage requested by load) and must be firmly connected to terminals without exposed parts which may cause shortcircuiting due to contact with metallic parts.
- C. The system must be free of short circuits.

ALARMS

- A. Alarm circuits must be wired correctly.
- B. Wiring for alarm connections must be firmly connected to terminals without exposed parts which may cause shortcircuiting due to contact with metallic parts.

7.2 ISOLATION TESTING

The PS1550 power system utilizes Y type filter capacitors for connections between inputs and ground. It has been accurately tested and isolation specifications have been verified. If isolation testing on PS1550 should ever become necessary, carry out operation in the following manner:

1. Disconnect input and output lines and alarm relays.
2. Shortcircuit Phase and Neutral (Positive and Negative) at input terminal for both inputs.
3. Shortcircuit Positive output with Negative.
4. Only use certified measuring instruments which furnish a controlled ramp rise (must be free of voltage steps) and no "spikes".
5. Isolation Input-Ground is carried out as per diagram shown in Fig. 11: applied voltage must be sinusoidal at maximum amplitude 2500 Vrms.
6. Isolation Output-Ground is carried out as per diagram in Fig. 12: applied voltage must be continuous at maximum value 500 Vdc.
7. Reconnect inputs, outputs and alarm relays to power system.

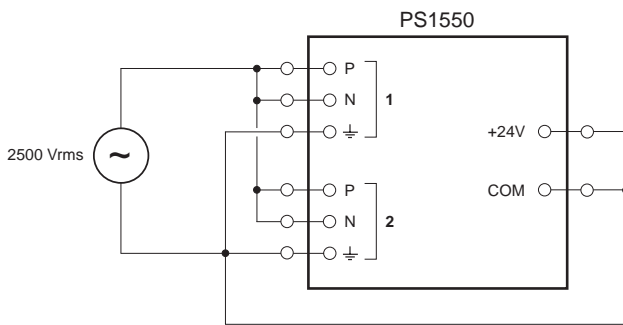

Fig. 11. Isolation Testing Inputs-Ground.

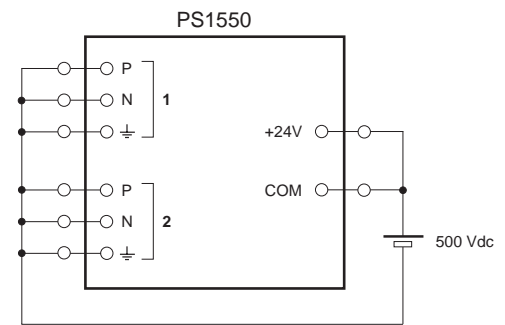

Fig. 12. Isolation Testing Output-Ground.

7.3 STARTING UP

After having carried out all preliminary controls it is then possible to utilize the PS1550.

It would be advisable to measure total current delivered at system output (utilizing a continuous ammeter) so as to be aware of the applied load and margins for future expansion.

In full load conditions it is necessary to verify ventilation system efficiency: see curve in Fig. 1.

8. MAINTENANCE

Maintenance operations must be carried out by qualified personnel.

Remember that certain parts of the power supply unit generate voltage up to 400 V, a potentially lethal situation. It is therefore strictly prohibited to remove any type of protection or to access internal parts of system when connected to mains. All Modules are extractable and can be individually inspected without having to open the chassis.

Improper connection of input Lines may provoke serious damage to system and associated equipment.

Verify that grounding connections are efficient to avoid risk of electrical shock.

Each line Module contains capacitors with a total capacity of 3300 μ F for Type-115, 1500 μ F and Type-230: such components loaded at working voltage accumulate lethal energy. Before extracting Modules it is therefore necessary to first disconnect them from Mother Board, then pull outward without actually extracting Modules so that they are only extracted 1 cm and leave them in this position permitting internal bleeder resistors to completely discharge capacitors.

The Power Modules also present input capacitance and require waiting at least half a minute before their extraction. In order to function correctly the system must be adequately cooled. It is extremely important that all air filters are kept clean and periodically check fan status (verify that air flow inlet/outlet are free from obstructions due to dust or grime, verify that fan rotation is correct, etc...). The fan box is readily accessible for inspection by extracting it from its housing and disconnecting wiring from mother board.

If steady accumulation of dust forms on Power Module dissipators, it is advisable to clean them by compressed air or after their extraction from rack, by brush.



8.1 SPARE PARTS

The availability of a stock of spare parts makes PS-1550 power system maintenance much easier. Given that the system is based on interchangeable units, on the spot maintenance or the substitution of defective parts or modules suspected of being defective is greatly facilitated including eventual shipment to Elcon for control and repair.

Recommended list of spare parts (Tab. 1).

Input and output terminal modules (respectively inserted in first and second housing slots) only contain trouble free passive components and do not require substitution under normal working conditions.

Description	Function for 115 V ELCON PN	Function for 230 V ELCON PN	Spare Parts % of installed parts
Line Module	1550 LM-115	1550 LM-230	3
Power Module	1550 PM-115	1550 PM-230	3
Line Module fuses 6,3x32 rapid 500 V	501035 (16A) 501040 (20A)	501034 (8A) 501039 (10A)	3
Power Module fuses 6,3x32 rapid 500 V	501036 (3.2A)	501033 (1.6A)	5
Axial fan	Fans 24 Vcc PN. 704005		5
Fuses (glass) for fan 5x20	500 mA PN. 501003		5
1550/FBD	Chassis with 3 fans 24Vcc and fault detection circuit		5

Table 1

8.2 REPAIRS

WARNING !

Repairs not directly carried out by Elcon Instruments are at the sole risk and responsibility of the user. In addition the terms stipulated in instrument warranty shall be considered null and void.

Refer to warnings cited in sections 6.1 and 8 and exercise every precaution in order to limit risk of fire and electrical shock by:

- Protecting the power line with easily accessible automatic switches.
- Utilization of an isolation transformer fitted with power fuse suitable for isolating circuit from mains power line.
- Connecting chassis to ground to avoid electrical shock.
- Isolating all exposed high voltage conductive parts with which it is possible to come into contact.
- Advanced planning of all maintenance interventions on high voltage sections of power system and application of suitable insulators as a safety precaution.



8.3 TROUBLESHOOTING

The PS1550 power system is fitted with luminous indicators (LED) and alarm relays which furnish useful indications on system function and help operator pinpoint principal causes of fault.

If the PS1550 is utilized with two line Modules it is possible, thanks to redundance, to extract or insert one of the modules without interrupting power output and see to its repair or substitution in case of breakdown. Even Power Modules can also be removed or inserted (hot-plug in) in rack without altering output.

The following table lists possible system malfunctions and corresponding LED status.

The customer is solely responsible for repairs carried out by the same and assumes all consequences and associated risks

LED status and corresponding malfunction diagnosis

Unit	LED on unit	LED status	Diagnosis
Input unit 1550/TB-IN	LED green "ON 1" "ON 2"	Both ON	Voltage Line 1 and Line 2 OK.
		OFF	Voltage drop on Line 1 or Line 2.
Line 1 Module 1550/LM	LED green "POWER ON"	ON	Voltage Line 1 OK; Line Module 1 OK.
		OFF	Voltage drop on Line 1 (also see LED on 1550/TB-IN 1); Line Module 1 fault.
Line 2 Module 1550/LM	LED green "POWER ON"	ON	Voltage Line 2 OK; Line Module 2 OK.
		OFF	Voltage drop on Line 2 (also see LED on 1550/TB-IN 2); Line Module 2 fault.
Power Module 1550/PM	LED green "OUT ON" (from 1 to 6)	ON	Power Module (from 1 to 6) OK.
		OFF	Power Module (from 1 to 6) fault or overload (also see overload LED status).
Power Module 1550/PM	LED red "OVERLOAD" (from 1 to 6)	ON	Power Module (from 1 to 6) fault or overload.
		OFF	Power Module (from 1 to 6) OK.
Fans units 1-2-3	LED green "FAN OK"	ON	Fans OK (current absorption within normal limits).
		OFF	Breakdown or overload of respective fan (current absorption too high or low).

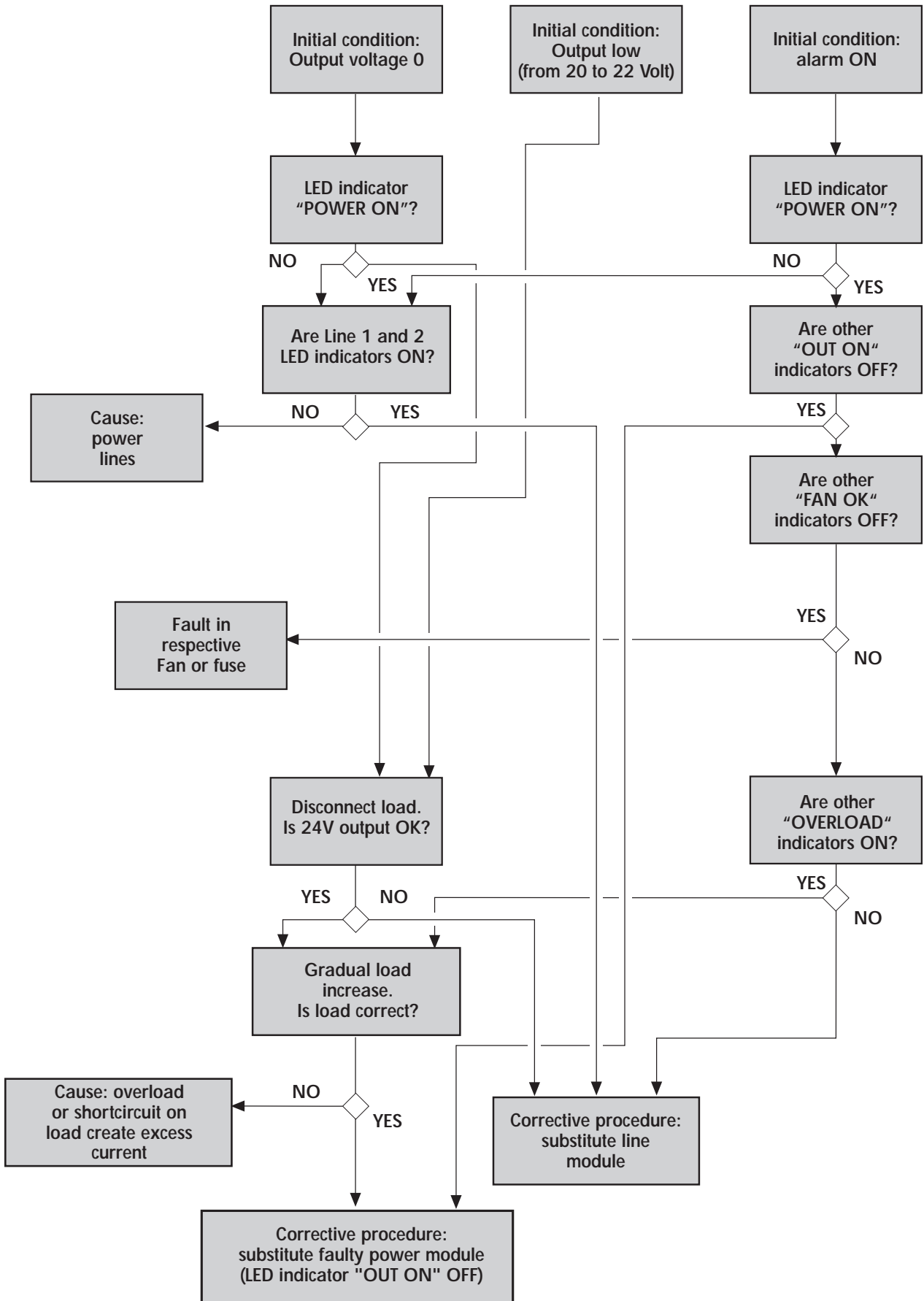



9. WARRANTY

Elcon offers an extended period of warranty assistance performed at their factory. Each instrument to be repaired is thoroughly analyzed to locate the cause and mode of possible faults and correlate them with the initial, intermediate and final testing documentation. This permits Elcon to trace the fault causes more accurately, thus obtaining valuable indications, reliability statistics, and qualitative evaluation for the purpose of maintaining the quality and reliability of the products under strict control.

WARRANTY CONDITIONS

Elcon Instruments certifies that all the instruments of their manufacture are free from defects or loss of essential quality. The duration of the warranty period is clearly indicated in the order confirmation and starts from the date of delivery or on site test (if required). Unless otherwise specified the warranty is for 12 months from date of delivery. The warranty does not cover expendable materials.

TERMS - CONDITIONS- WARRANTY LIMITS

1. Form of report

Any action attributable to the customer due to flaws, defects, or loss of quality is subject to the terms of articles 1495,1497 C.C. (Italian Civil Code).

The declaration or reporting of the, defect or quality loss must be made by the customer by registered mail, telex, fax, or equivalent written form to be sent to the main office of Elcon Instruments.

2. Limit - burden - obligation of the customer to conserve the warranty

a) The warranty is limited to repairing and substitution, FOB Elcon Instruments factory, of unusable parts, for a confirmed defect of materials and/or workmanship, free of charge, and the remaining, shipping, dismantling and reassembly expenses (operations that in any case must be done in accordance with the supplier), at the customer's charge.

In no case will Elcon Instruments be held responsible for expenses, for loss of profit and/or damage, direct or indirect, that can be incurred by the customer due to a fault or defect of the material.

b) The warranty is considered invalid for instruments or materials damaged during:

- shipment
- storage in non conformance with instruction manual specifications
- incorrect installation
- loss of adequate protection for the type of installation (mechanical, climatic, etc.)
- incorrect application of power supply voltage
- erroneous wiring of the power supply line (applied on input or output measuring circuits)

c) The warranty ends for instruments or materials if repaired, modified, or simply tampered with, even if only in part, by personnel not authorized by Elcon Instruments and also ends if used in improper way and/or not conforming with the given instructions.

d) The warranty is valid only if payment has been received from the customer in a timely fashion, as per the original agreement; otherwise it is void.

e) All parts that are subject to normal wear and their inevitable deterioration is excluded from this warranty.

f) In case of having to return the instrument to one of the Elcon Instruments authorized labs for repair, the customer shall obtain a written authorization with shipping instructions from Elcon Instruments.

Shipment expenses, all the concerned burdens, and the risk of loss or damage of the returned instrument are exclusively born by the customer.

The same rules apply also when the instrument needs to be replaced.

g) During the warranty period, the customer will allow any personnel appointed by Elcon Instruments to control instruments and materials.



h) The customer cannot request cancellation of the contract due to flaws or defects, but only their elimination or, when they cannot be repaired, the replacement of the instruments, if available . If however replacement is not possible, Elcon Instruments has the faculty to offer instruments of the same or equivalent type, quality and efficiency, suitable to the same use.

If the customer refuses such offer without justified motivation he is entitled to reimbursement of the money already paid or a refund of real incurred expenses.

- i) For items subsupplied by Elcon Instruments the standard warranty terms as given by the original manufacturer are applicable.
- j) The warranty must be considered for material repaired, substituted on ex works basis.

Such warranty replaces and supersedes any other declared or implicit warranty.